

ARCH BY MARKUS JOHANSSON & JOHAN LINDSTEN,
BLOCKCHAIN & CIRRATA BY MARKUS JOHANSSON,
BALANCE BY VICTOR CASTANERA, MONDO BY ANTONIO
FACCO, TRAPEZE BY JETTE SCHEIB, NOTIC & STAIR BY
NOTCHI ARCHITECTS, HELIOS BY JOAKIM THEDIN,
LIGHTBONE BY FÄRG & BLANCHE, INSIDE 2.0
BY MORTEN & JONAS

2024 / 2025

oblure

SWEDEN

oblure

The name Oblure is a union between the words “Object” and “Allure”. The concept lays in the core of the brand in order to design and create alluring objects. Oblure was founded in 2017 in Gothenburg, Sweden with the desire to bring new innovative products in the field of lighting.

With our skills and roots that are cemented in the Scandinavian design tradition we endorse the simplicity, the minimalistic, and the functional but it does not end there. In the spirit of creativity, we want to add furthermore. For us a lamp is so much more than just light, it’s a piece of art.

We therefore collaborate with international designers with our focus on creating a collection of products that shine a distinguishable character and celebrates innovative elements that not just surprise but also intrigue the beholder. Our vision is to curate the original, the bold and the beautiful.

BLOCKCHAIN SYSTEM

The Blockchain System consists of aluminum cubes, attached together apparently random. A single cube traveling through time and space – rendering a sequence of positions for the beholder. But there is order in chaos, a millimeter precision to create this perfect silhouette. Every second cube is equipped with a custom-made LED panel designed and directed to spread a uniform light on whatever is below.

The cubes form an abstract silhouette in angles seemingly floating in the air. Blockchain system comes in various of length, starting from 1200 mm up to 3000 mm continues line, or your own creative way of angles. Designed, engineered and handcrafted in Sweden, locally in Greater Gothenburg Metropolitan, the Swedish west coast.

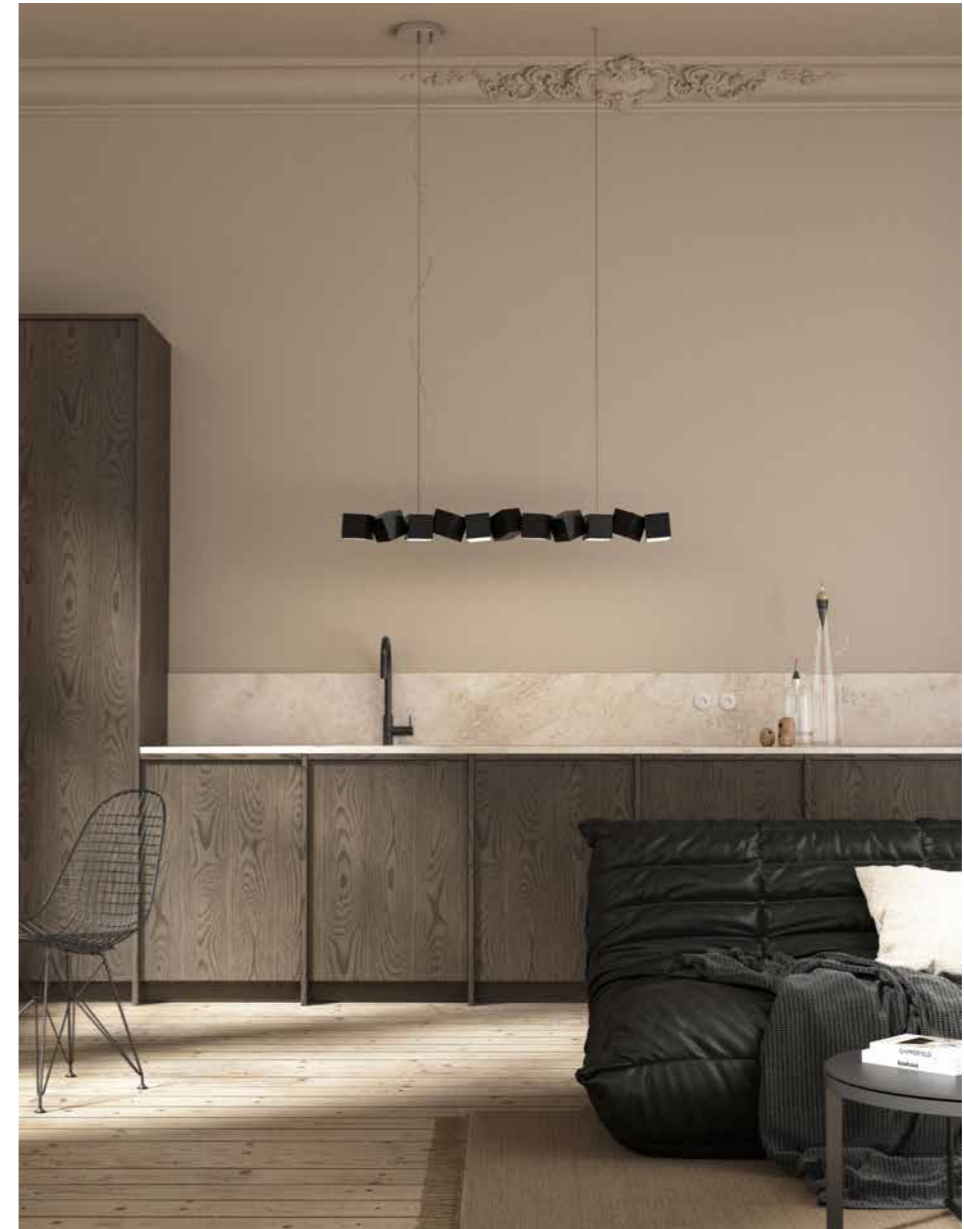

BLOCKCHAIN 11 / BLACK PENDANT



BLOCKCHAIN 29 / BLACK / PENDANT



BLOCKCHAIN 17 / BLUE / PENDANT

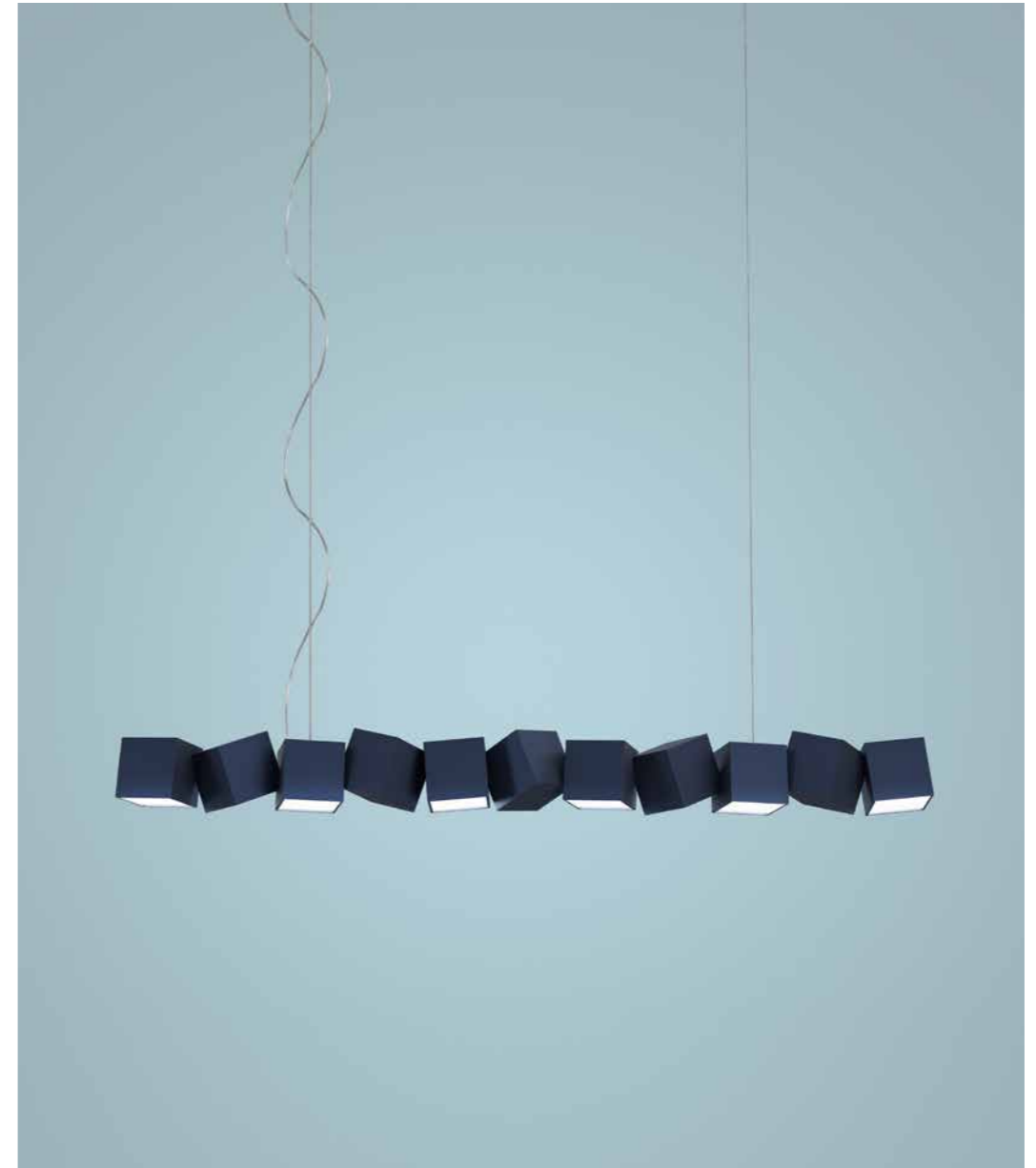

BLOCKCHAIN 11 / BLUE / PENDANT



BLOCKCHAIN 11 / BLACK / PENDANT

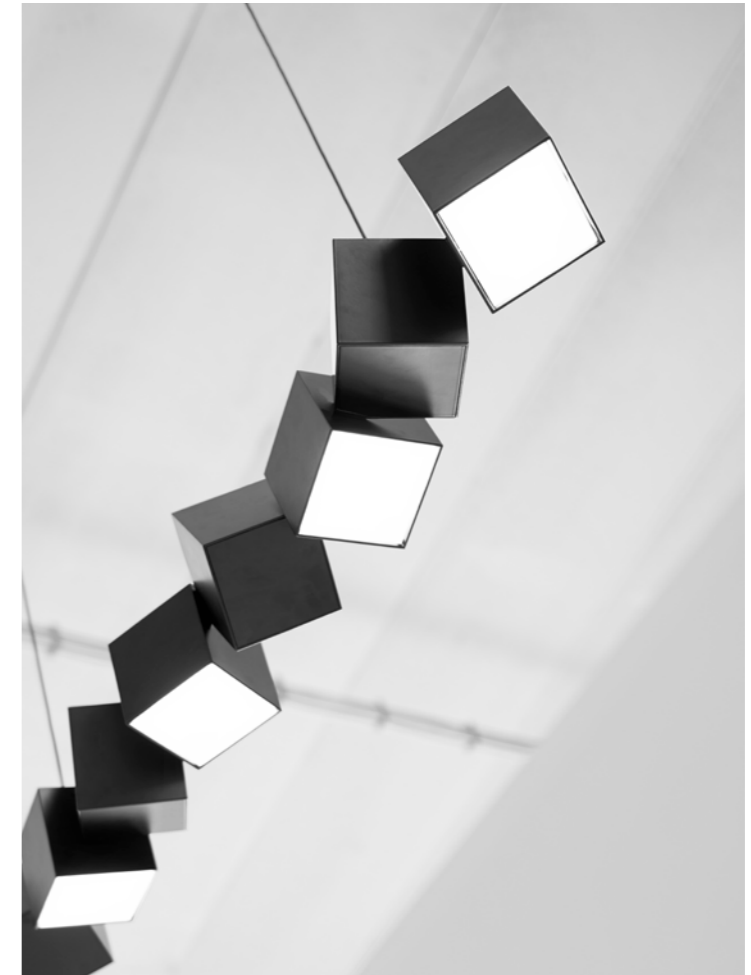

Markus Johansson (Sweden)
graduated in 2011 from HDK
(School of Design and Crafts) in
Gothenburg, Sweden. Markus work
with both Swedish and international
brands and has won numerous awards
and is represented at The Museum of
Art and Design, New York.

LIGHTBONE

The Lightbone, a creation by FÄRG & BLANCHE, made its debut at the Armour Mon Amour exhibition during Milan Design Week 2017. Initially showcased in fabric and soaring up to 3 meters in height, these lamps drew inspiration from an unforgettable journey through Japan and its bamboo forests.

”We are thrilled to unveil the latest evolution of the LightBone floor lamp in collaboration with Oblure, this time crafted in solid oak wood and proudly made in Sweden,” shares the design duo, Färg & Blanche. This new version not only marks a transition in material, embracing the richness of solid oak, but also signifies our unwavering dedication to quality craftsmanship and sustainability.

Expanding upon the Lightbone family, we are proud to introduce the Lightbone pendant/ceiling collection, available in sizes small, medium, and large.

Each size encapsulates the essence of the original floor lamp, featuring the same meticulous design and solid oak wood construction. Additionally, these pendant/ceiling lights are thoughtfully equipped with a spotlight for downlight, adding a versatile touch to their luminous charm.

The Lightbone lights represent a harmonious blend of cultural inspiration and contemporary design. Whether showcased individually or grouped together, these lights create an enchanting ambiance, transforming your space into a sanctuary of style and sophistication.

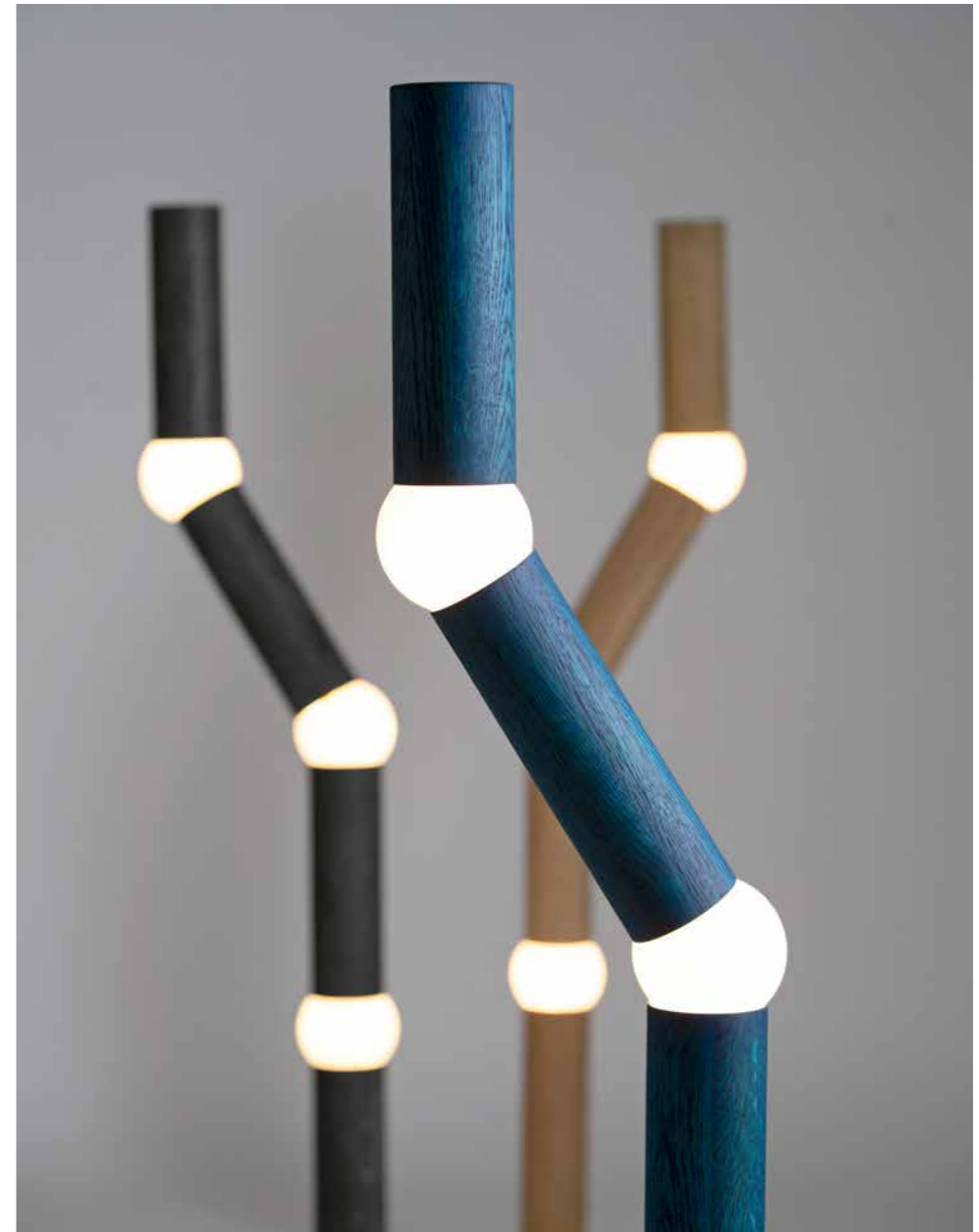

LIGHTBONE / FLOORLAMP



LIGHTBONE / NATURAL OAK / FLOORLAMP

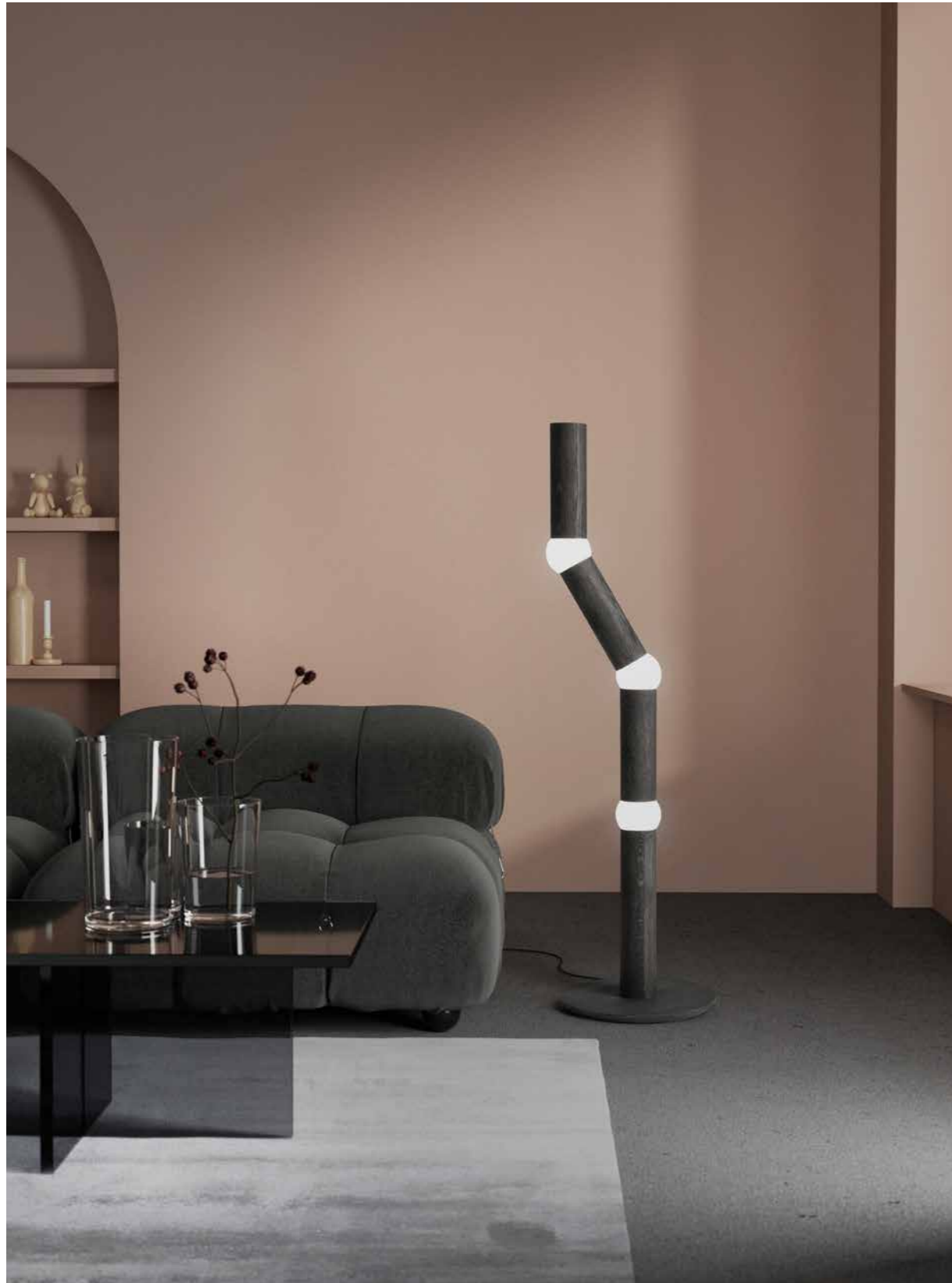

LIGHTBONE / BLACK OAK / FLOORLAMP



LIGHTBONE / NATURAL OAK / FLOORLAMP



LIGHTBONE / BLACK OAK / MEDIUM CEILING

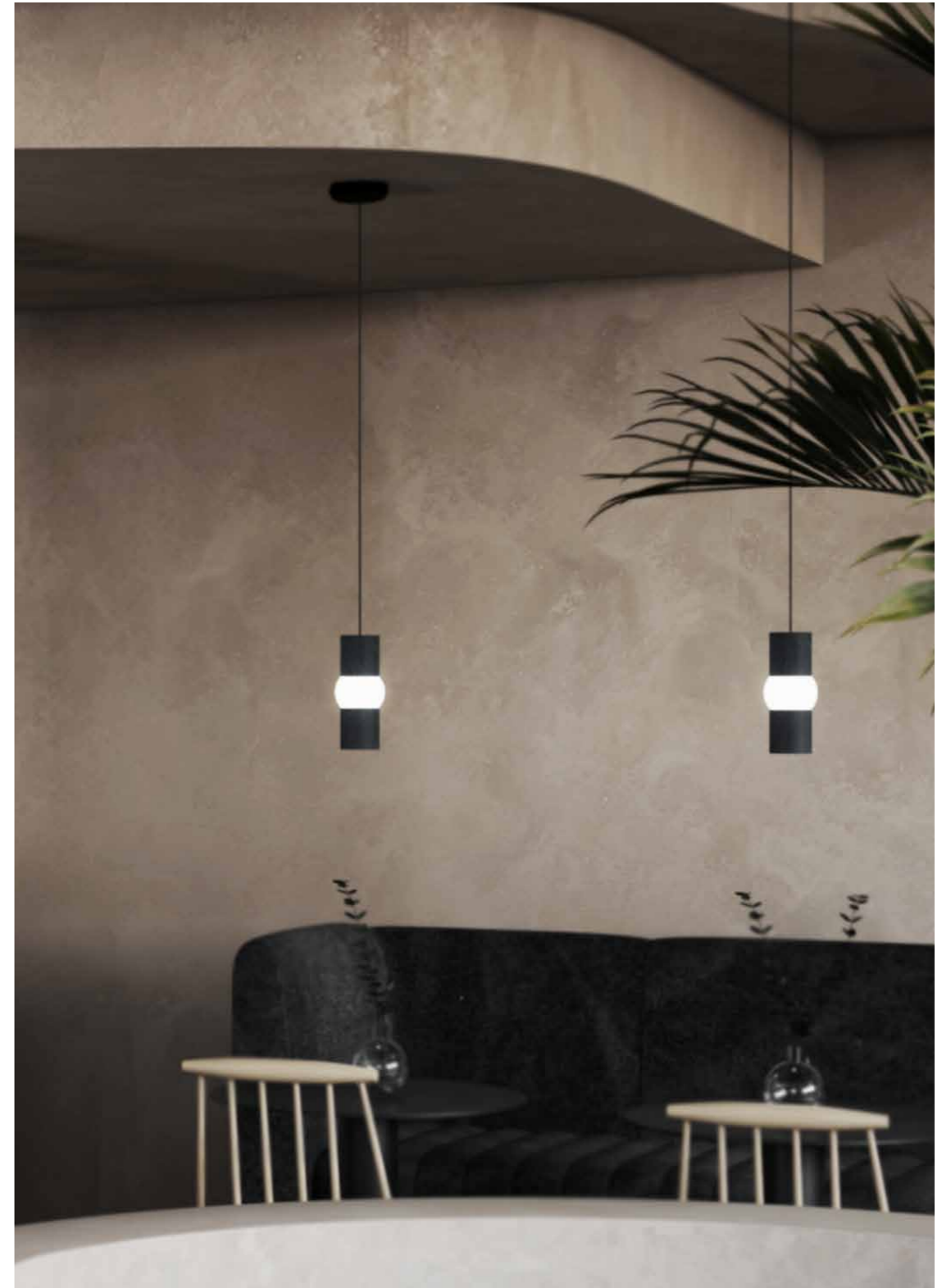

LIGHTBONE / BLACK OAK / SMALL PENDANT



LIGHTBONE / NATURAL OAK / MEDIUM CEILING AND PENDANT LAMP



LIGHTBONE / NATURAL OAK / SMALL CEILING LAMP



LIGHTBONE / NATURAL OAK / MEDIUM AND LARGE PENDANT



LIGHTBONE / BLACK OAK / SMALL PENDANT LAMP



LIGHTBONE / BLUE OAK / MEDIUM AND LARGE PENDANT



FÄRG & BLANCHE (Sweden) was founded in 2010 by the Swedish designer Fredrik Färg and designer Emma Marga Blanche, born in France. As a studio, they work across a wide variety of fields, collaborating with established furniture brands such as BD Barcelona Design, Gärnsnäs, Rörstrand, Petite Friture and Design House Stockholm to name a few, as well as producing their own collections and limited art pieces for galleries.

SUPERWAVE

Superwave brings to mind the ever-changing sea and how it can be translated into a strict geometry. The wave-shaped diffuser is not only a visual delight, but also designed to create optimal light distribution with high glare comfort.

Simultaneously, the uplight facet graces the ceiling with a soft, ambient radiance. This upward illumination imparts an air of spaciousness, transforming even the most compact spaces.

The wires that suspend the fixture are not just practical but also contribute to its visual allure. Whether it hangs over the dining table or in the office landscape, Superwave is a pendant that impresses with strong visual appearance and functionality.

Superwave features in four standard colors. Furthermore, for a truly personalized touch, the pendant can be customized in any color of your choosing, providing you to align it seamlessly with your unique aesthetic vision.

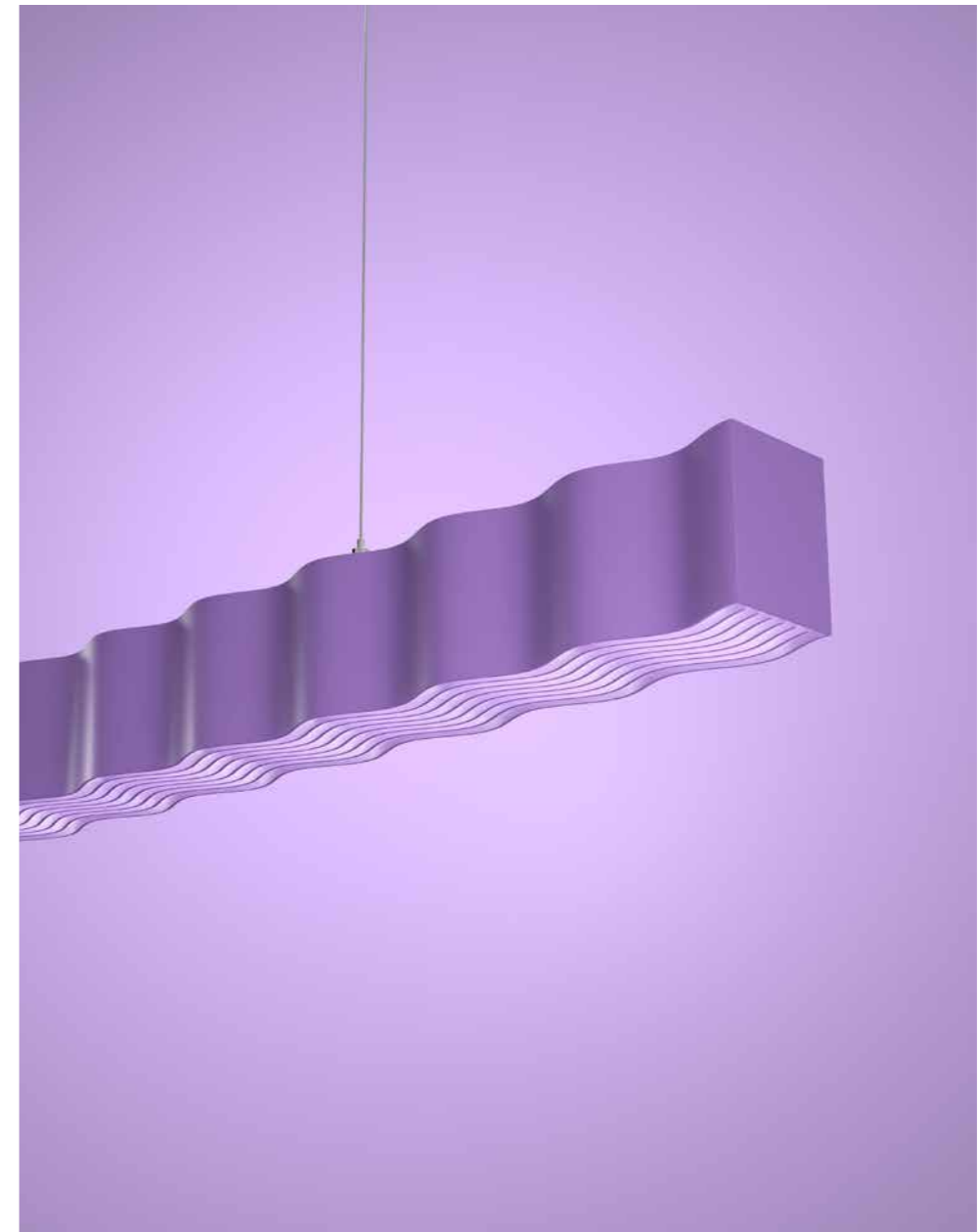

SUPERWAVE / LILAC / PENDANT



SUPERWAVE / CUSTOM COLOR / PENDANT

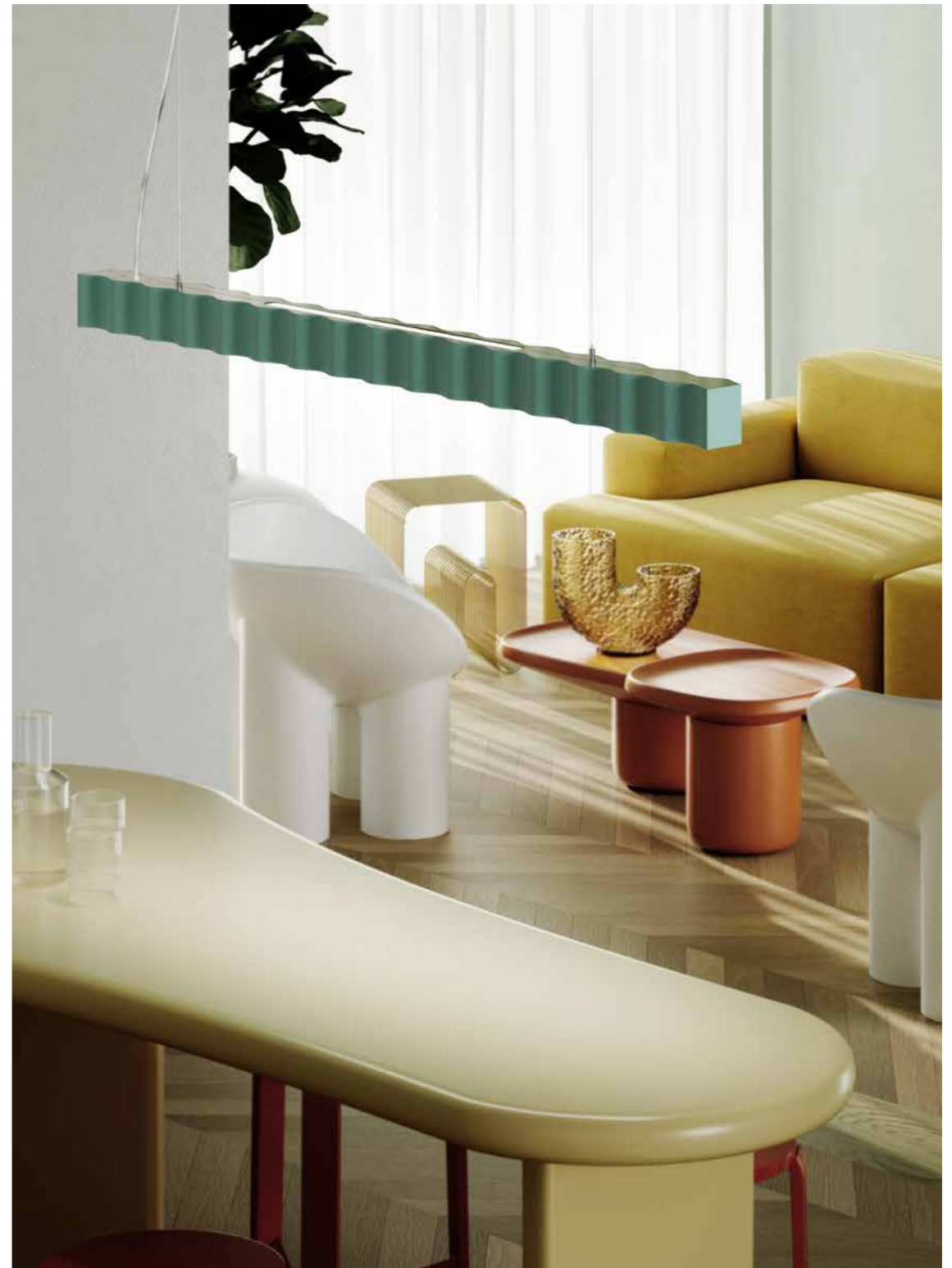

SUPERWAVE / MINTGREEN / PENDANT



SUPERWAVE / WHITE / PENDANT

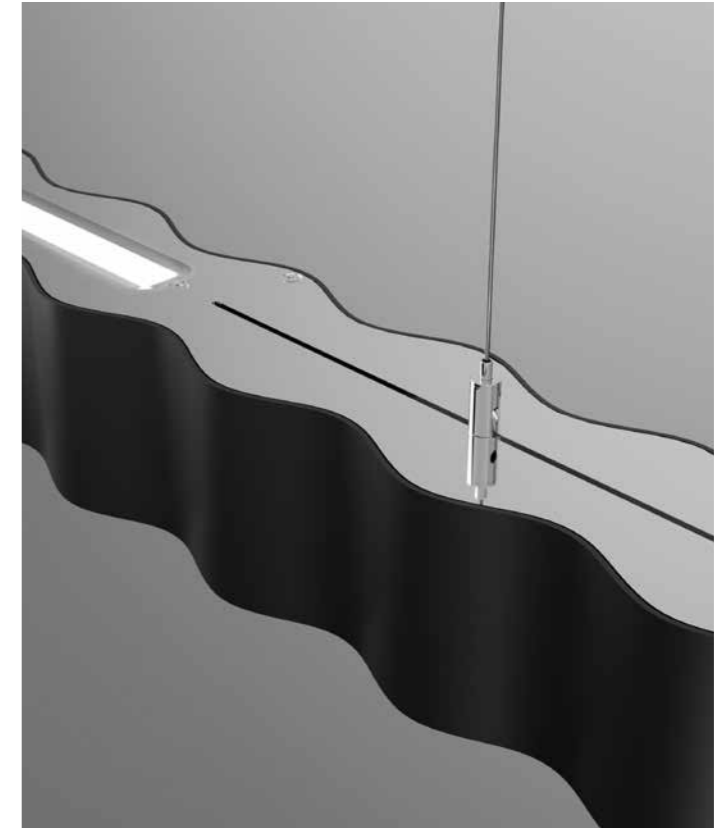

Notchi Architects (Sweden) integrates architecture and visual arts. Working with products, installations and architecture, the understanding of the relation between space and object is strong and the quest to find the right objects for a specific space sometimes results in new products.

STAIR LAMP

STAIR draws inspiration from the basic geometry of a solid stair block. The sphere creates curiosity while resting on the edge of time. A ``snapshot`` of movement in a series of events creates a strong symbolic look. When the globe is lit, it results in a beautiful shadow play.

The distinctive shape hides a set of functions as Stair is equipped with two USB-C ports on the side. In a digital world where people see technology as a matter of course, this provides many user possibilities.



STAIR / RED / TABLE LAMP



STAIR / YELLOW AND RED / TABLE LAMP

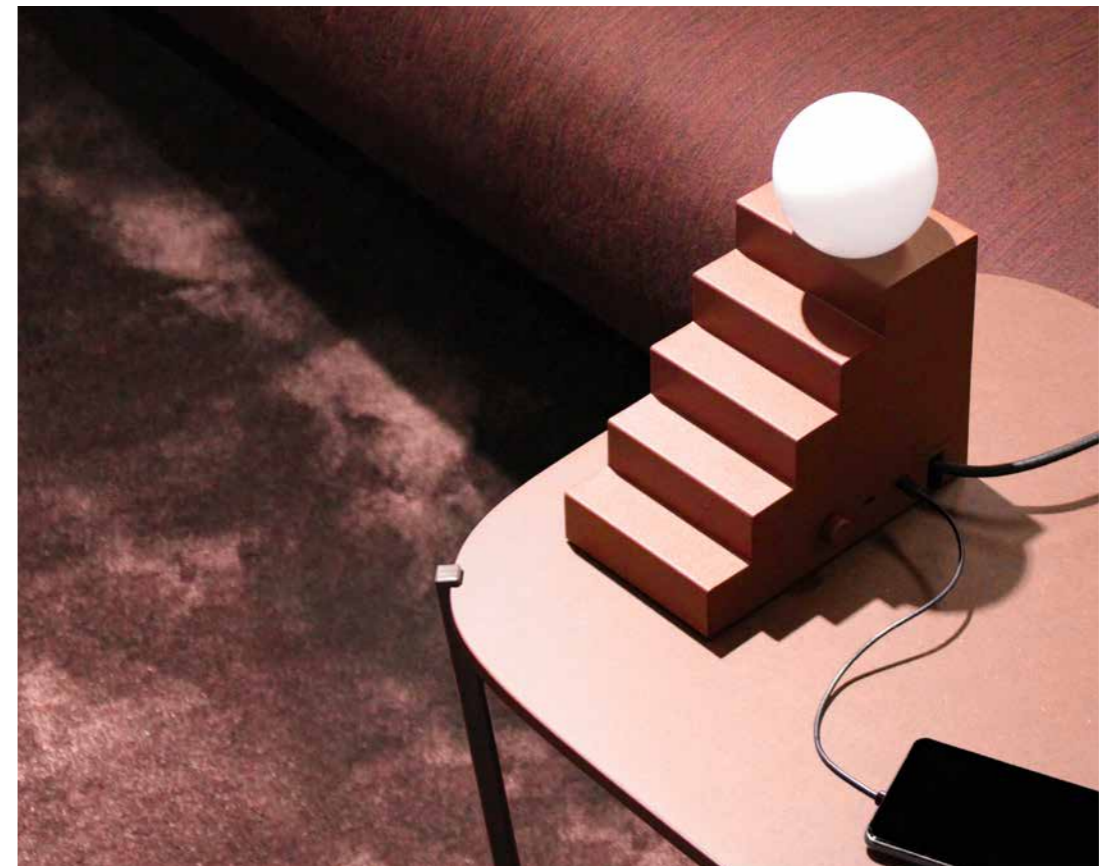

STAIR / RED / TABLE LAMP



STAIR / RED / TABLE LAMP

Photo and styling by Teklan

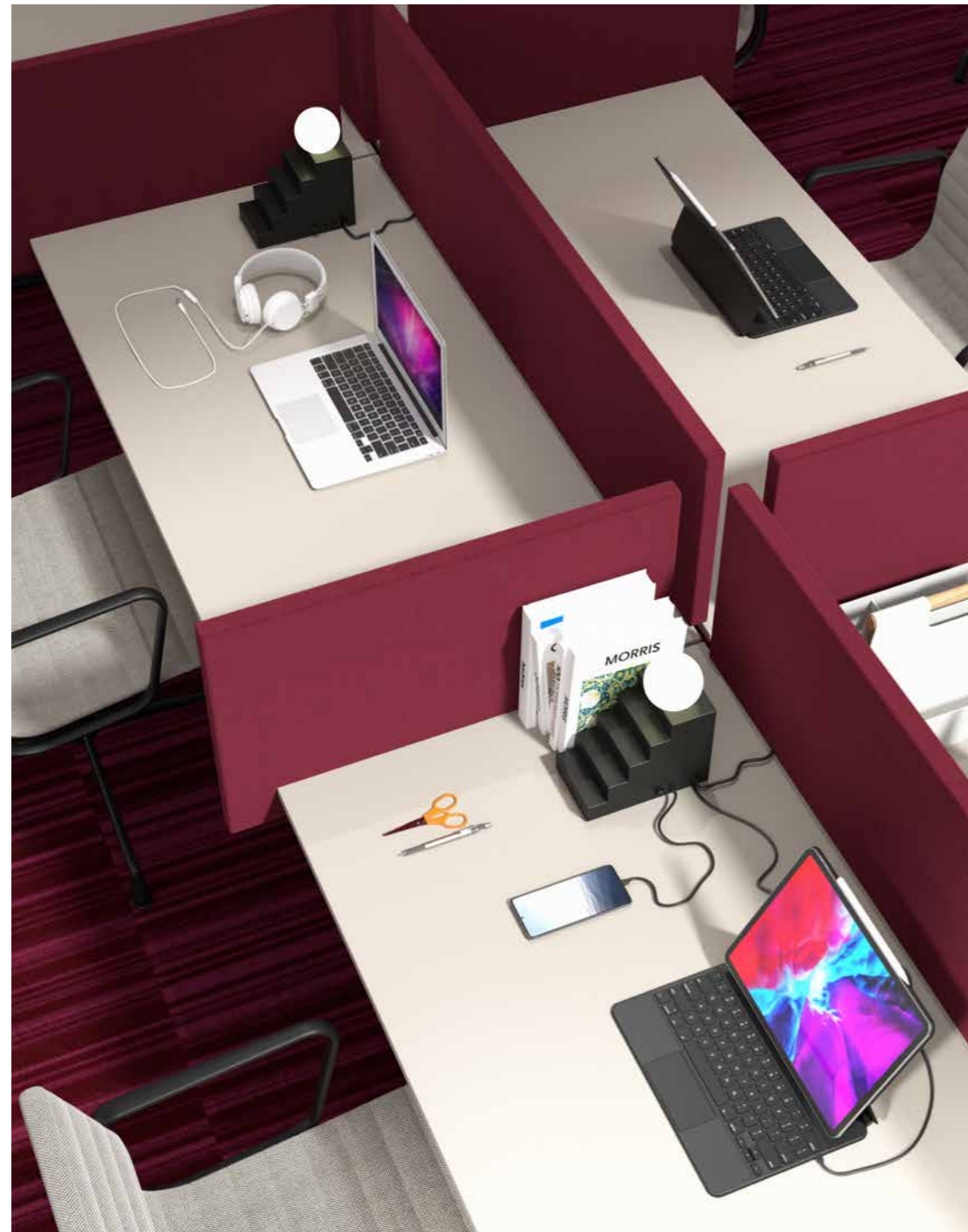

STAIR / BLACK / TABLE LAMP

Notchi Architects (Sweden) integrates architecture and visual arts. Working with products, installations and architecture the understanding of the relation between space and object is strong and the quest to find the right objects for a specific space sometimes results in new products.



BALANCE

All entities move and nothing remains still. Balance plays with the concept of time - everything is in motion. The impossible position of the orbs is an expression of the fragility of existence. The group of spheres stuck in time is a reminder to the beholder that life always moves, no matter what.

The construction is made from of a pair of glowing orbs poised between two slanted steel boards. The metal spheres seen on both sides have just the right density to counterweight the opposite part of the lamps' weight. The overall structure is grounded on a robust foundation.



BALANCE / BLACK / TABLE LAMP



Victor Castanera (Spain) loves to experiment and the search for the different and emotional often result in the use of new techniques and materials. Living and working in Barcelona the Mediterranean culture is a big inspiration as well as his passion for the nature and the sea. The result is a collection of objects and products that speak for themselves in the simplest possible way.

ARCH

An arch shape travels from light to light, and in its entirety, the pendant resembles and shows appreciation for the architectural arches and vaults that have been built for centuries. Each pillar features a downlight with precise glare control. The fixture has an alluring and eye-catching design that consists of a metal exterior in multiple colors. Arch Straight quickly became a favorite, and it wasn't long before several constellations were in demand.

Now, evolving into a circular form, the lamp attains its design culmination with diameters of 760mm and 980mm, closing the circle in its proper sense. Arch continued to earn acclaim, leading to demand for various constellations.

Welcoming the delightful additions, Arch Single and Arch Triplette, these siblings complement the family.

"We view these members as an extension, contributing to the Arch's evolution into a cohesive family."



ARCH STRAIGHT / BLUE / PENDANT



ARCH STRAIGHT / BLACK / PENDANT



ARCH STRAIGHT / BLACK / PENDANT



ARCH SINGLE & TRIPLETTE / WHITE / PENDANT

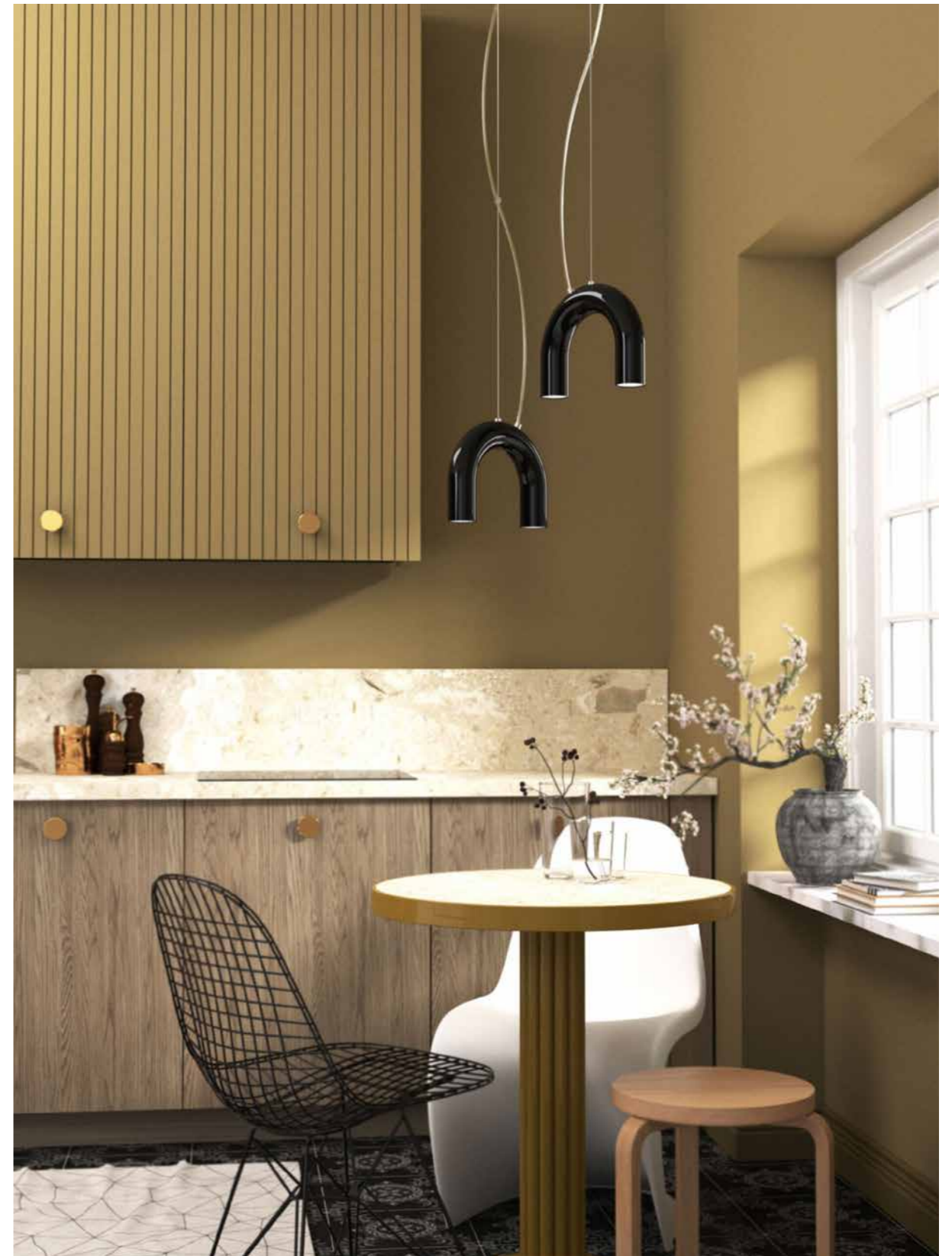

ARCH SINGLE / BLACK / PENDANT

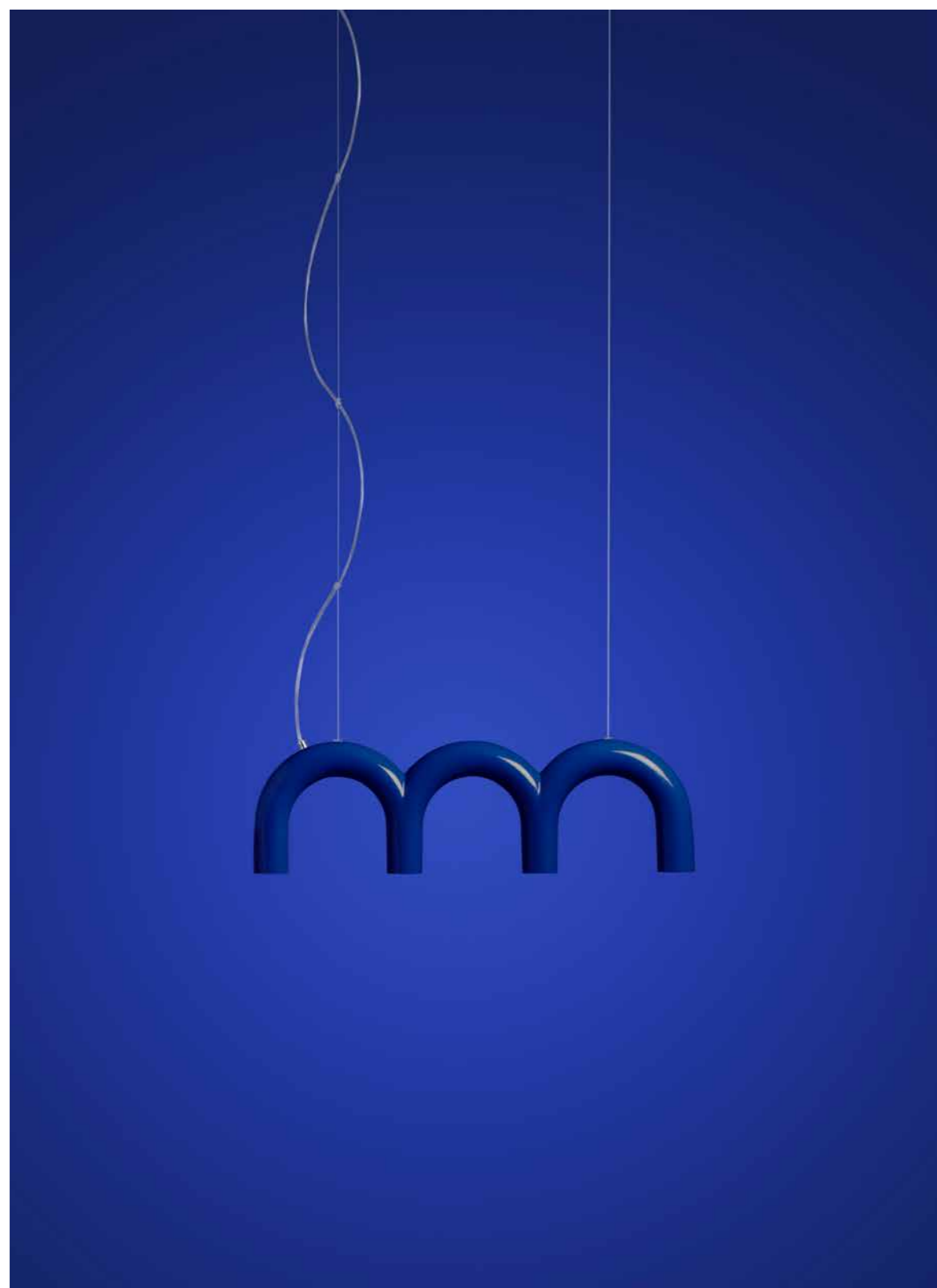

ARCH TRIPLETTE / BLUE / PENDANT



ARCH TRIPLETTE / BLUE / PENDANT



ARCH CIRCLE 980 / NUDE / PENDANT

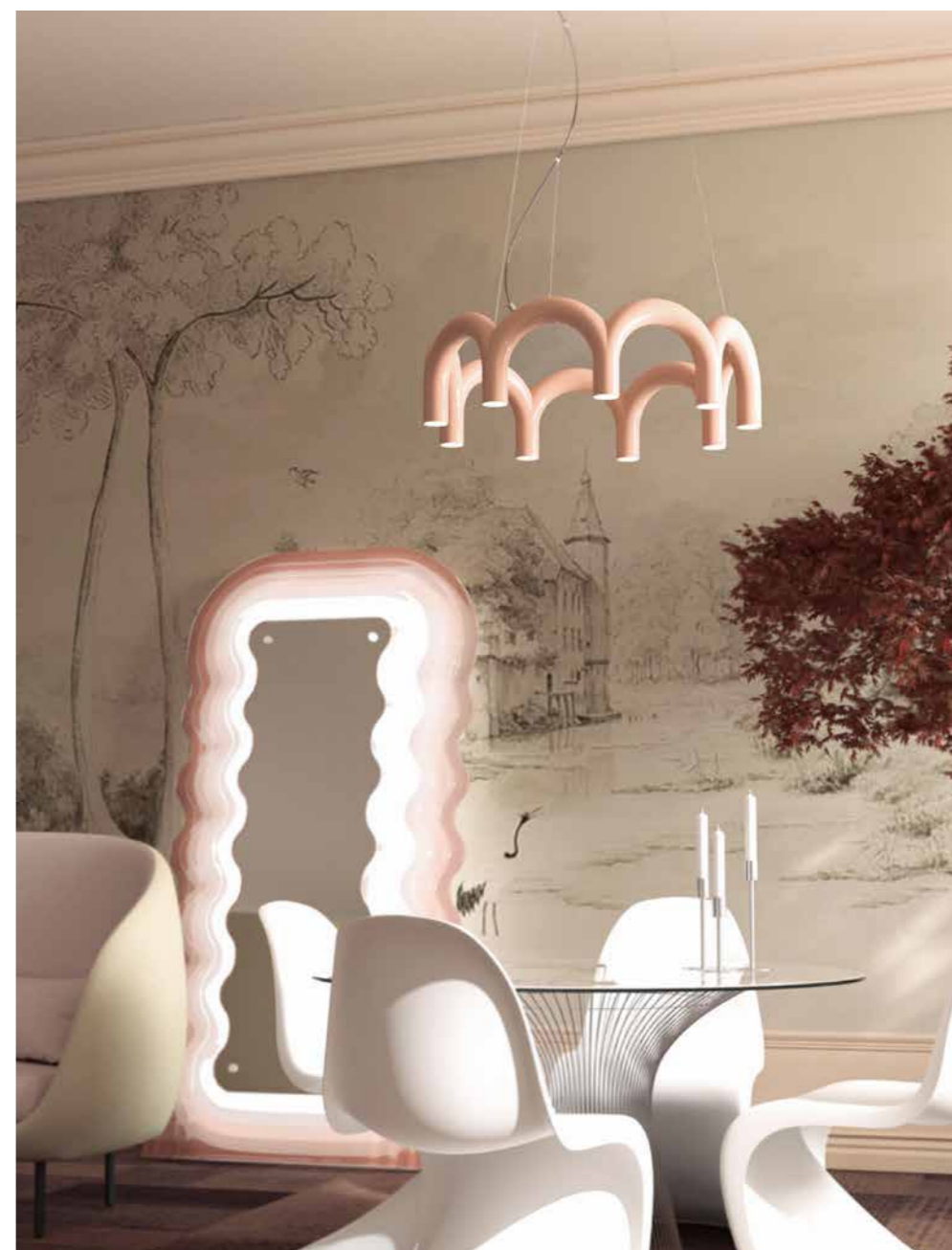

ARCH CIRCLE 760 / NUDE / PENDANT



ARCH CIRCLE 760 / CUSTOM COLOR / PENDANT



ARCH CIRCLE 980 / CUSTOM COLOR / PENDANT



ARCH STRAIGHT / WHITE / PENDANT



Johan Lindsten (Sweden) was born in 1981 in the heart of, 'Möbelriket', the furniture kingdom of Sweden. Profiting from a vast knowledge about the industry at an early age he successfully graduated in the program of furniture design in Stockholm in 2008, leading to the establishment of the independent Design Studio Johan Lindstén Form.

Markus Johansson (Sweden) graduated in 2011 from HDK (School of Design and Crafts) in Gothenburg, Sweden. Markus work with both Swedish and international brands and has won numerous awards and is represented at The Museum of Art and Design, New York.

MONDO

Mondo pendant has a classic soul but contemporary ambitions. It combines a planetary physical image with an abstract concept of originality programmed by the beholder. The possibility of interacting with the lamp offers the user an infinite dialogue.

The overlapping patterns control the luminous effect through the movement of the metallic shades. Antonio Facco has created a sophisticated lamp that invites the user to become a co-designer.





MONDO / BLACK / FLOORLAMP



MONDO / BLACK / PENDANT



Antonio Facco (Italy) always paid great attention to the evolution of contemporary design and communication. Through the analysis of new generations' behavior and habits he draws hints and inspiration for his own research and projects. Antonio is strongly connected to Cassina furniture brand and with his own studio, he work across a wide variety of fields, collaborating with other well established furniture brands such as BOLON, Mogg to name a few.

TRAPEZE

Trapeze is a true artist, an aerialist combining grace and style. Fixed in a single pose with endless possibilities. Each shade can be directed 360 degrees which allows the user to combine uplight and downlight at the same time. A playful and bold feature that also is pragmatic and practical in use.

Trapeze is available in three versions. The single pendant with two shades, the 'triple' with six shades or the 'quartette' with eight shades. All these fixtures makes it possible to adjust and direct the light where it is needed.



TRAPEZE / BLACK / PENDANT



TRAPEZE TRIPLETTE / BLACK / PENDANT





Jette Scheib (Germany) studied Industrial Design at the University of the Arts in Berlin. "I am inspired by nature and organic shapes, but also by people and everyday life. I am observing my surroundings, I study objects, people, people interacting with objects and each other."

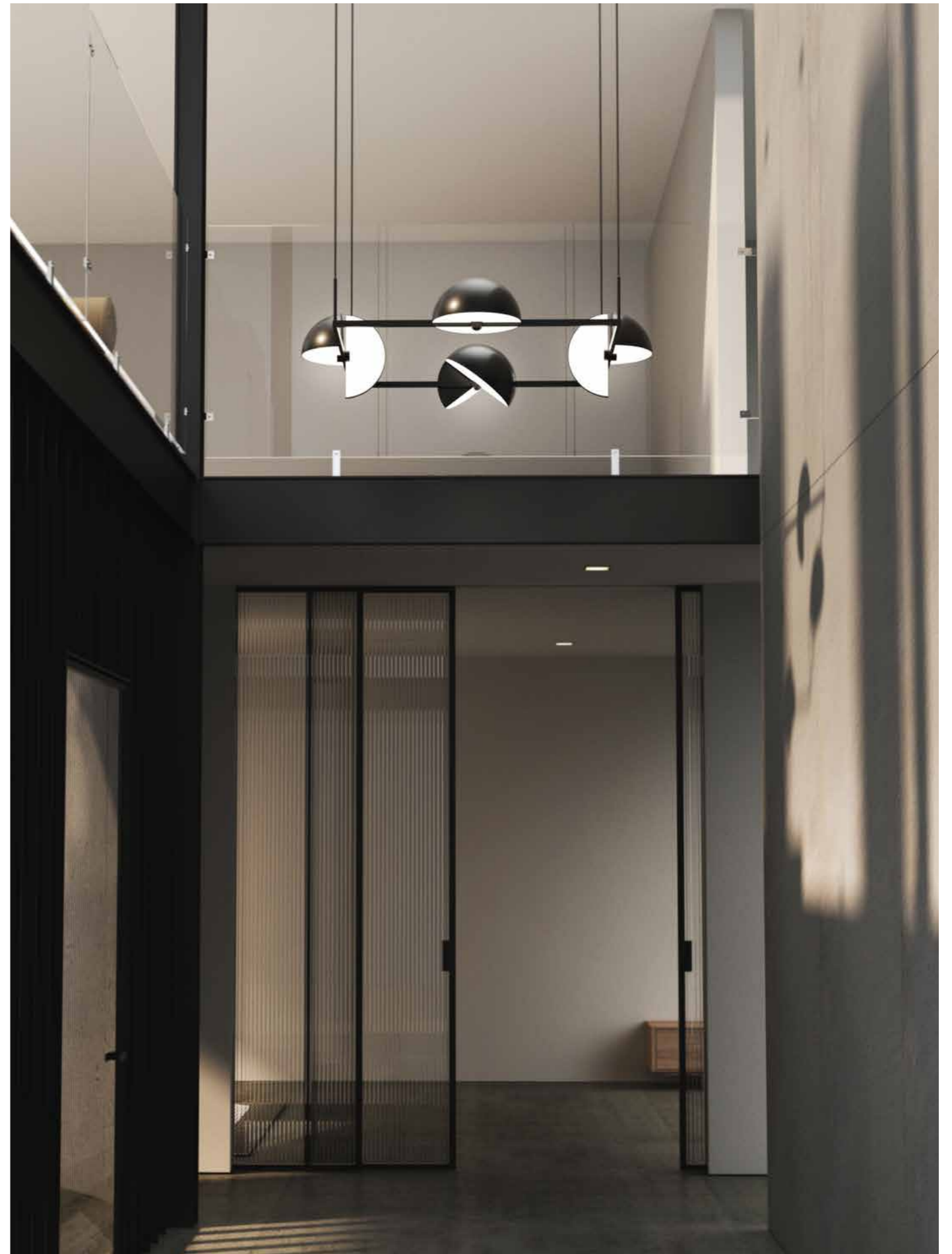

HELIOS

Helios is an aspiration to reinvent the classical chandelier – but instead of reflecting and diffusing, the rods project and enhance the light. Each of the 240 acrylic rods are lit by an individual LED, hidden in the center of the lamp.

The pendant is two faced – when turned off Helios has a cold and crisp appearance. Turned on, the lamp comes alive, and the intensity of the many acrylic rods portray a glowing sphere resembling the sun. An almost transcendental appearance.



HELIOS / PENDANT



HELIOS / PENDANT



Joakim Thedin (Sweden) has been working as a product designer since 1997, both with objects for public and home environment. The last years he has been focusing on light design and has mainly worked with Swedish brands. Helios is his first product for Oblure.

CIRRATA

Unexpected experiences and surprises wait deep down on the ocean floor: a body with many arms lights up the depth. Arrogant and presumptuous, there is no doubt about who is the ruler down here. A lonely but nevertheless unafraid character with forms born out of their resemblance to other inhabitants of the unknown.

The character is *Cirrata*, a glowing lamp in the darkness of the ocean. Markus Johansson has created a lamp that challenges all ideas about what is possible to make out of aluminium. The symmetrical arms equally carry the weight of the lamp.

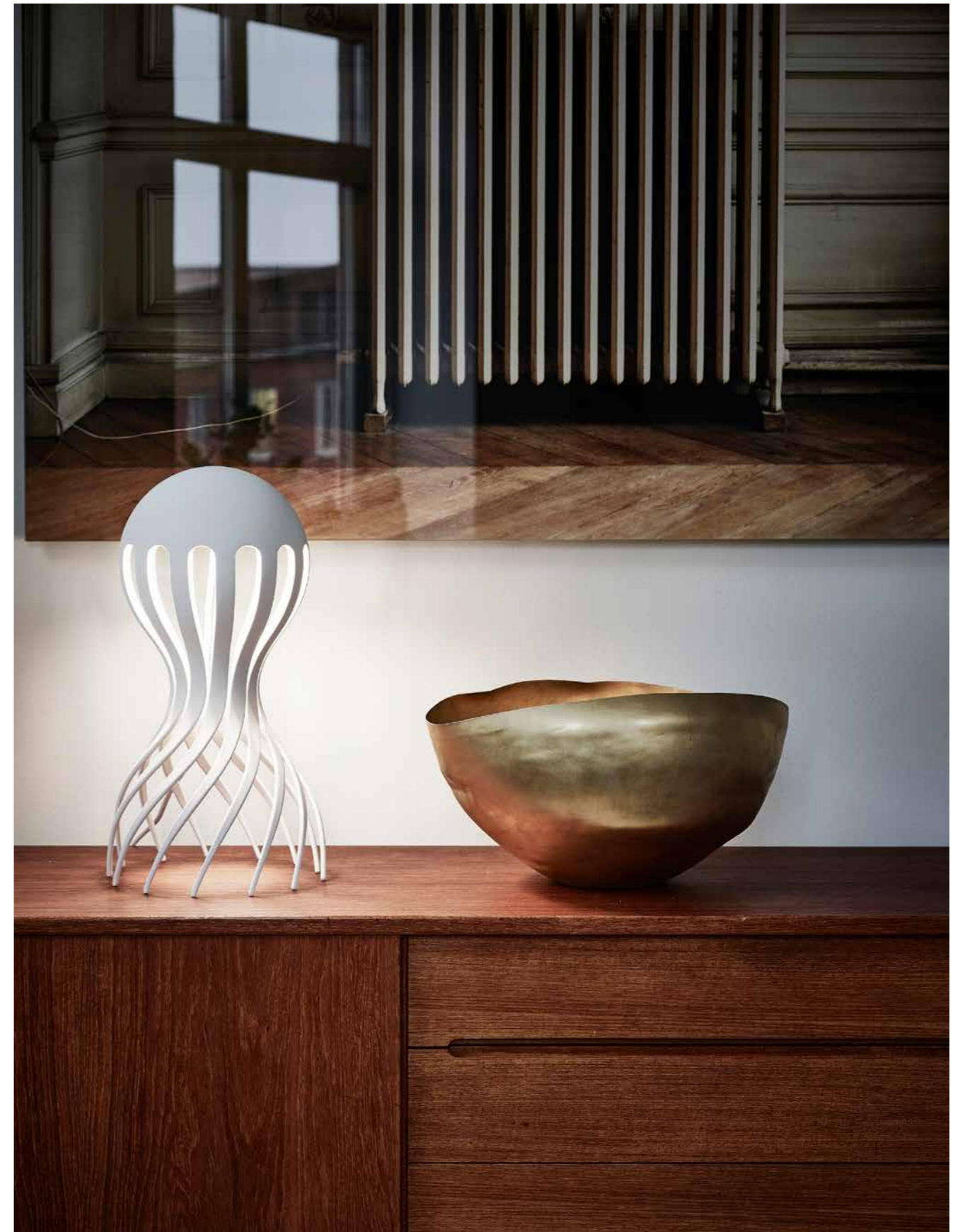

CIRRATA / WHITE / PENDANT



CIRRATA / GREY / PENDANT



Markus Johansson (Sweden) graduated in 2011 from HDK (School of Design and Crafts) in Gothenburg, Sweden. Markus work with both Swedish and international brands and has won numerous awards and is represented at The Museum of Art and Design, New York.

NOTIC

Notic is an homage to classical architectural elements. The graphical metal shade embraces the complex geometry of the glass and spreads the light in a hypnotic way. The lamp has a focused down light combined with a gentle illumination through the shade. With the resemblance of a hypnotic pendulum the beholder might even find something within themselves.

The idea behind the lamp was to design a focus point in a three-dimensional space. A room needs virtual lines and directions to guide the visitor but also to create defined spatiality. The pattern does not only work as a design element and a way to spread the light, the sharp contrast also draws immediate attention.



NOTIC / BLACK / WALL LAMP



NOTIC / BLACK / PENDANT



NOTIC / BLACK / TABLE LAMP



NOTIC / BLACK / TABLE LAMP



Notchi Architects (Sweden) integrates architecture and visual arts. Working with products, installations and architecture the understanding of the relation between space and object is strong and the quest to find the right objects for a specific space sometimes results in new products.

INSIDE 2.0

Inside pendant is a tribute to the most generous and kind lady in the city of Bergen, Norway. The pendant is an attempt to materialize her genuine enthusiasm, passion and knowledge about design into a single object.

The name comes from the twisted glass. The shape makes every lamp unique diffusing and spreading the light in a gentle wave pattern. The pattern is an extension of the design and what makes Inside so special.



INSIDE 2.0 / PENDANT

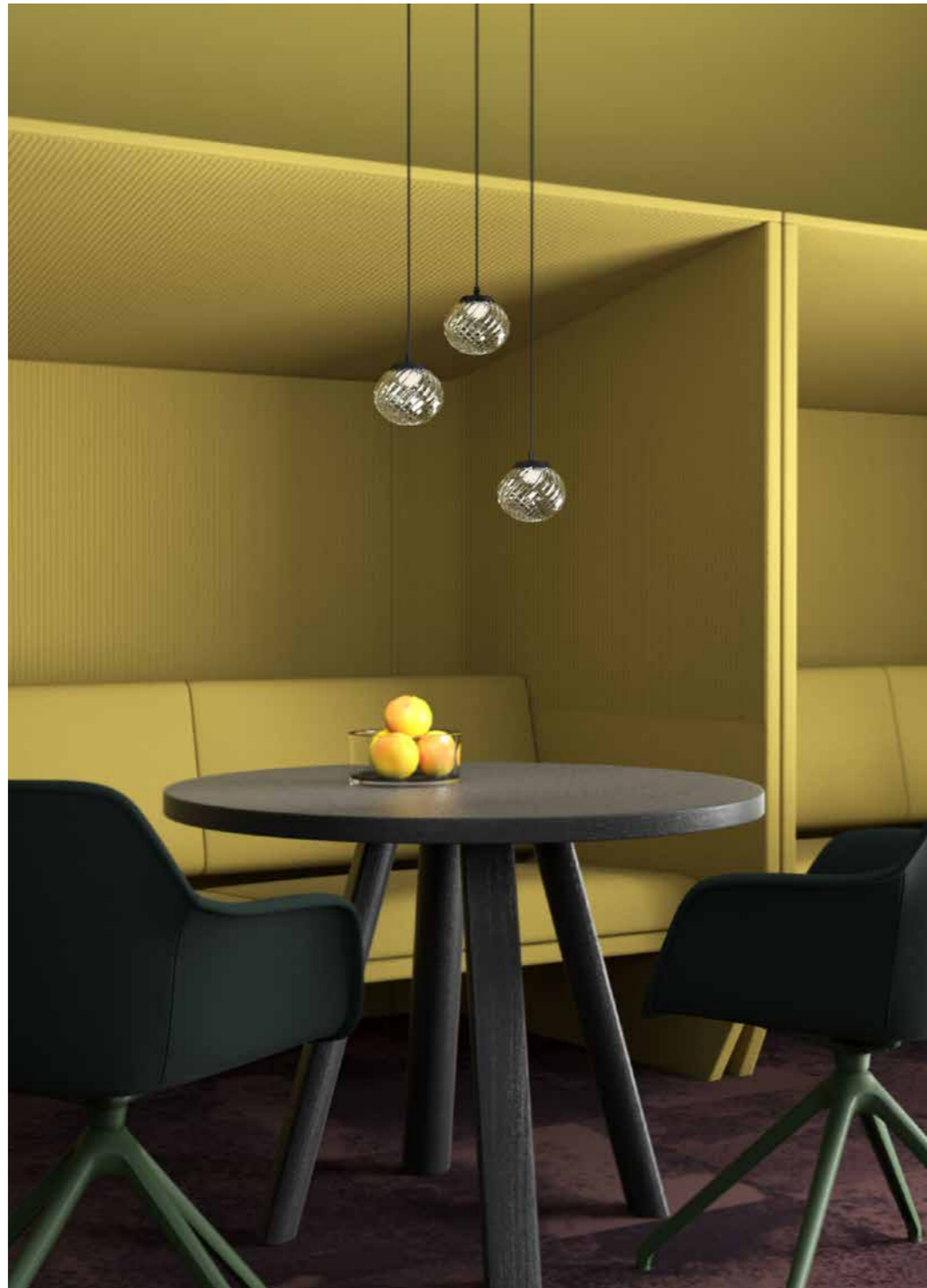

INSIDE 2.0 TRIPLETTE / PENDANT



Notchi Architects (Sweden) integrates architecture and visual arts. Working with products, installations and architecture the understanding of the relation between space and object is strong and the quest to find the right objects for a specific space sometimes results in new products.

TECHNICAL SPECIFICATIONS

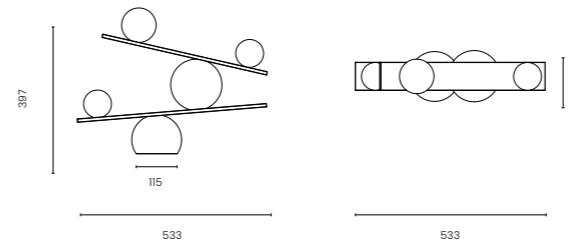



Balance Table Lamp (2016) P. 40

Victor Castanera (Spain)

Description: Table lamp in steel with two opal glass. Glossy black paint (Black) and plated brass (Brass). With interchangeable multi wall plug adapter for multi country use.

Environment: Indoor
 Watt: 5,5 w (3,5w + 2w)
 Measurements: 397 mm (H), 533 mm (L), 140 mm (W)
 Cord: 180 cm
 LED info*: Custom LED (included and replaceable)
 CCT 2700K, dimmable, CRI 90, 50.000h

Colors:	Black	VCBA1003	
	Brass	VCBA1010	
	Chrome	VCBA1011	

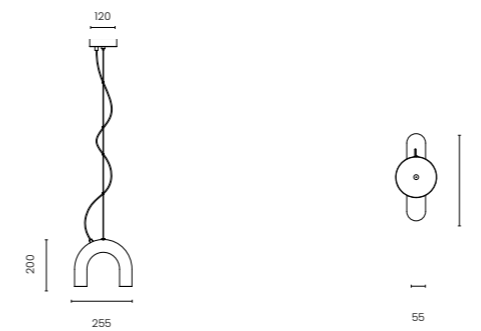





Arch Single Pendant (2021) P. 48

Johan Lindsten (Sweden), Markus Johansson (Sweden)

Description: Pendant lamp in steel, bent and welded by hand. Each pillar is equipped with GU10 sockets. The lamp suspension details are in chrome finish, as well as the ceiling canopy. Suspension wires are adjustable with a griplock® and power cable in transparent cover.

Environment: Indoor
 Watt: max 2 x 20 W (LED)
 Measurements: 200 mm (H), 255 mm (L), 55mm (W)
 Cord: 300 cm
 Fitting: GU10 (PAR16 Light bulb not included)

Colors:	White	MJAR2001.S	
	Black	MJAR2003.S	
	Blue	MJAR2006.S	
	Nude	MJAR2008.S	
	Custom	MJAR2000.SXX	

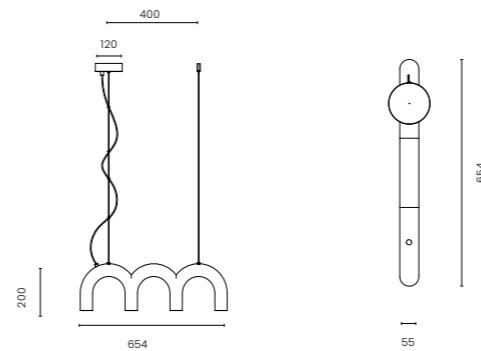

Arch Triplette Pendant (2021) P. 48

Johan Lindsten (Sweden), Markus Johansson (Sweden)

Description: Pendant lamp in steel, bent and welded by hand. Each four pillars are equipped with a GU10 socket. Suspension fittings are in chrome finish, as well as the ceiling canopy. Suspension wires are adjustable with an griplock® and power cable in transparent cover.

Environment: Indoor
 Watt: max 4 x 20 W (LED)
 Measurements: 235 mm (H), 654 mm (L), 55 mm (W)
 Cord: 300 cm
 Fitting: GU10 (PAR16 Light bulb not included)

Colors:	White	MJAR2001.T	
	Black	MJAR2003.T	
	Blue	MJAR2006.T	
	Nude	MJAR2008.T	
	Custom	MJAR2000.TXX	

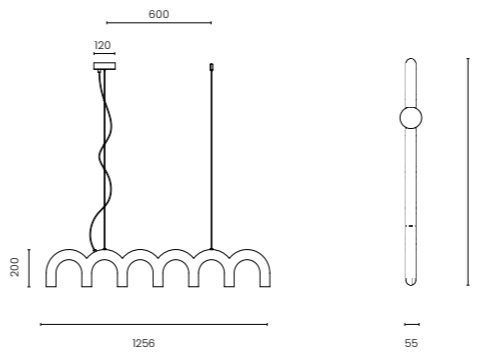





Arch Straight Pendant (2021) P. 43

Johan Lindsten (Sweden), Markus Johansson (Sweden)

Description: Pendant lamp in steel, bent and welded by hand. Each seven pillars equipped with GU10 sockets. The lamp suspension details are in chrome finish, as well as the ceiling canopy. Suspension wires are adjustable with a griplock® and power cable in transparent cover.

Environment: Indoor
 Watt: max 7 x 20 W (LED)
 Measurements: 200 mm (H), 1256 mm (L), 55mm (W)
 Cord: 300 cm
 Fitting: GU10 (PAR16 Light bulb not included)

Colors:	White	MJAR2001	
	Black	MJAR2003	
	Blue	MJAR2006	
	Nude	MJAR2008	
	Custom	MJAR2000.XX	



LED info*: Updated and detailed information, please see product sheet or website.

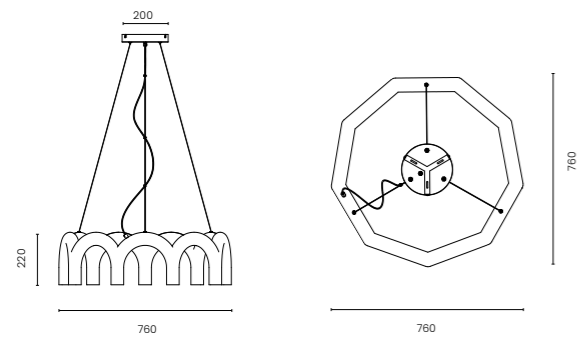

Arch Circle 760 (2021) P. 53

Johan Lindsten (Sweden), Markus Johansson (Sweden)

Description: Circle pendant lamp in steel, bent and welded by hand. Each nine pillars are equipped with a GU10 socket. Suspension fittings are in chrome finish, as well as the ceiling canopy. Suspension wires are adjustable with a griplock® and power cable in transparent cover.

Environment: Indoor
Watt: max 9 x 20 W (LED)
Measurements: 220 mm (H), 760 mm (Ø)
Cord: 300 cm
Fitting: GU10 (PAR16 Light bulb not included)

Colors: White MJAR2001.C1 ●
Black MJAR2003.C1 ●
Blue MJAR2006.C1 ●
Nude MJAR2008.C1 ●
Custom MJAR2000.C1.XX ●

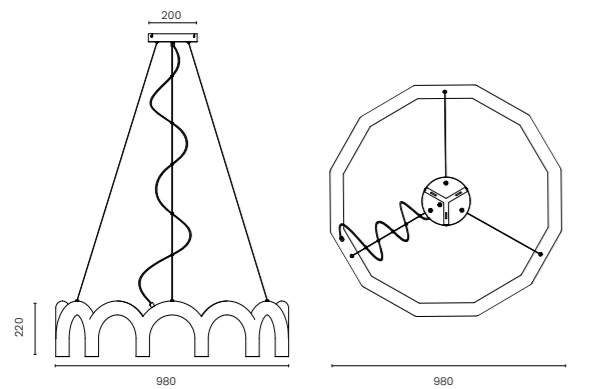

Arch Circle 980 (2021) P. 52

Johan Lindsten (Sweden), Markus Johansson (Sweden)

Description: Pendant lamp in steel, bent and welded by hand. Each eleven pillars are equipped with a GU10 socket. Suspension fittings are in chrome finish, as well as the ceiling canopy. Suspension wires are adjustable with a griplock® and power cable in transparent cover.

Environment: Indoor
Watt: max 11 x 20 W (LED)
Measurements: 220 mm (H), 980 mm (Ø)
Cord: 300 cm
Fitting: GU10 (PAR16 Light bulb not included)

Colors: White MJAR2001.C2 ●
Black MJAR2003.C2 ●
Blue MJAR2006.C2 ●
Nude MJAR2008.C2 ●
Custom MJAR2000.C2.XX ●

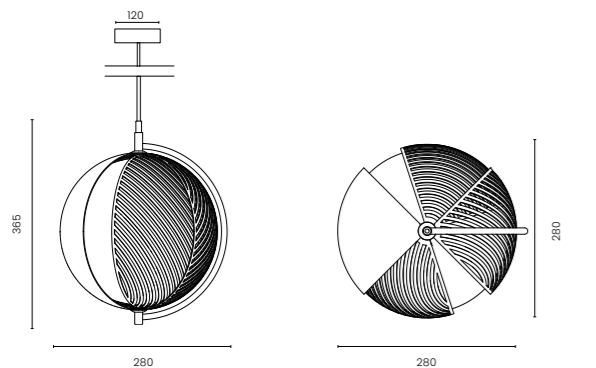
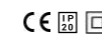

Mondo Pendant (2018) P. 57

Antonio Facco (Italy)

Description: Steel and opal glass. Pendant lamp with four metal shades, mounted in pairs. Allows the beholder to interact with the lamp.

Environment: Indoor
Watt: Max 40w
Measurements: 365 mm (H), 280 mm (Ø)
Cord: 300cm
Fitting: E27 (Light bulb not included)

Colors: Black AFMO2003 ●

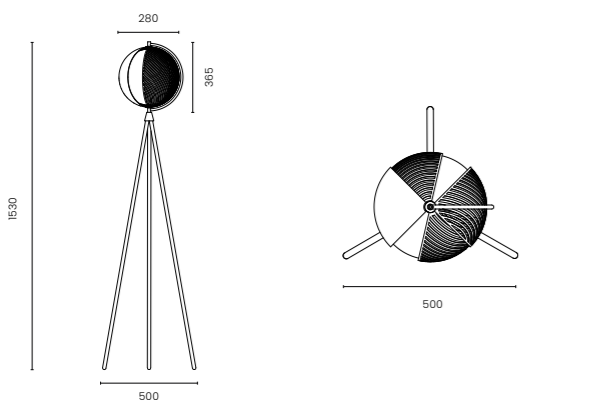

Mondo Floor (2018) P. 58

Antonio Facco (Italy)

Description: Floor lamp with four metal shades, mounted in pairs. Allows the beholder to interact with the lamp. Cable with on-off switch.

Environment: Indoor
Watt: Max 40w
Measurements: 365 mm (H), 280 mm (Ø)
(Shade/glass) 1530 mm (H), 500 mm (Ø)
(Height/base)
Cord: 180cm
Fitting: E27 (Light bulb not included)

Colors: Black AFMO3003 ●



LED info*: Updated and detailed information, please see product sheet or website.

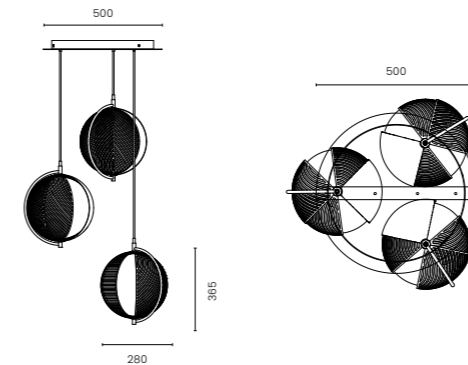

Mondo Triplette (2018) P. 62

Antonio Facco (Italy)

Description: Configuration of three Mondo pendants. The movable shades allow the beholder to interact with the lamp. Finished with matt Black paint.

Environment: Indoor
Watt: Max 3 x 40 W
Measurements: Each lamp: 365 mm (H), 280 mm (Ø), Canopy: 500 mm (Ø), 38 mm (H)
Cord: 300cm
Fitting: E27 (Light bulb not included)

Colors: Black AFMO2003-X3 ●

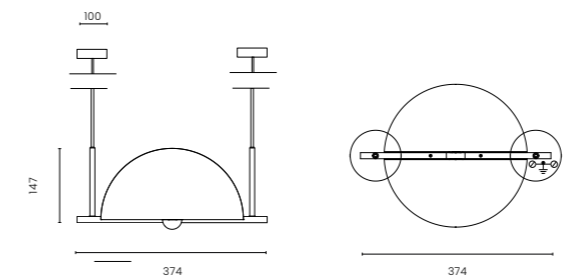

Trapeze Pendant (2018) P. 65

Jette Scheib (Germany)

Description: Steel with acrylic diffuser. Pendant lamp providing light in two different directions at the same time. Rotate each shade individual. Ceiling cup with textile cable (1 electric terminal block).

Environment: Indoor
Watt: Max 2 x 20 W
Measurements: 374mm (H), 281 mm (W), 147 mm (H)
Cord: 300cm
Fitting: 2 x E14 (Light bulb not included)

Colors: Black JSTR2003 ●

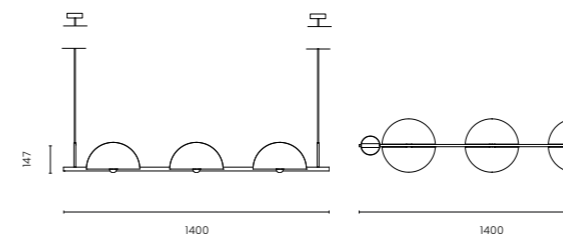

Trapeze Triplette (2018) P. 66

Jette Scheib (Germany)

Description: Steel with acrylic diffuser. Pendant lamp providing light in six directions at the same time. Rotate each shade individual. Ceiling cups with textile cable (1 electric terminal block).

Environment: Indoor
Watt: Max 6 x 20 w
Measurements: 1400 mm (L) x 281 mm (W) x 147 mm (H)
Cord: 300cm
Fitting: 6 x E14 (Light bulb not included)

Colors: Black JSTR2003-X3 ●

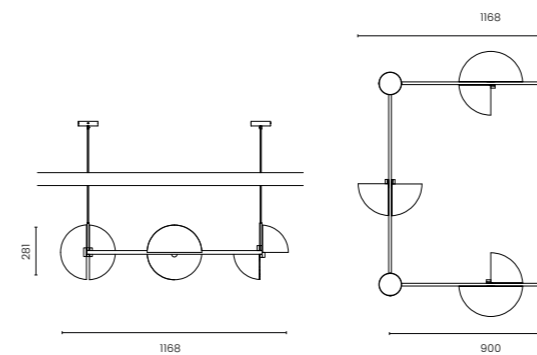

Trapeze Quartette (2018) P. 69

Jette Scheib (Germany)

Description: Steel with acrylic diffuser. Pendant lamp providing light in eight directions at the same time. Rotate each shade individual. Ceiling cups with textile cable (1 electric terminal block).

Environment: Indoor
Watt: Max 8 x 20 w
Measurements: 900 mm tube. 1168mm total length x 281 mm (H)
Cord: 300cm
Fitting: 8 x E14 (Light bulb not included)

Colors: Black JSTR2003-X4 ●



LED info*: Updated and detailed information, please see product sheet or website.

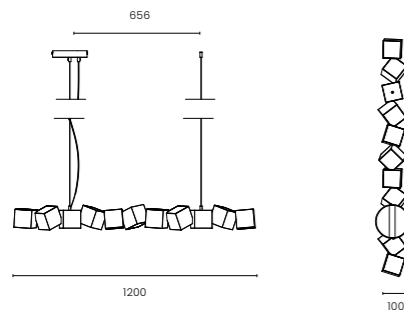

Blockchain 11 (2019) P. 5

Markus Johansson (Sweden)

Description: Pendant lamp providing downlight from every second cubes. Dimmable LED driver (trailing edge) is provided and fitted in the canopy. Steel wire suspensions and transparent cable.

Environment: Indoor
 Watt: 6 x 5 W
 Measurements: 1200 mm (L), 100 mm (W), 100 mm (H)
 Cord: 300 cm
 LED info:* LED (replacable-spare part)
 lm output 2400 lm , CCT 3000K, SDCM 3, CRI 90, L90>100.000h, Driver: Pushdim, DALI

Colors: Black MJBL2003-X11 ●
 Blue MJBL2006-X11 ●

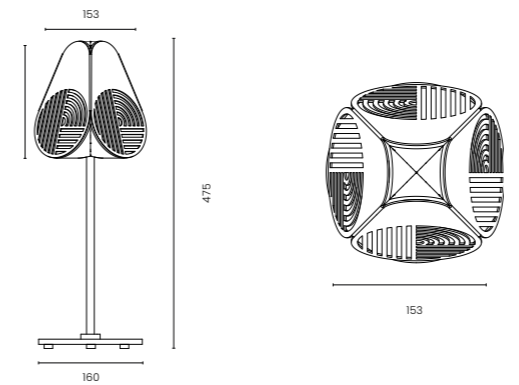

Notch Table Lamp (2019) P. 82

Notchi (Sweden)

Description: Table lamp in patterned steel and casted opal glass. Complex geometry, textile cord.

Environment: Indoor
 Watt: Max 25 W
 Measurements: 475 mm (H), 153 mm (W), 153 mm (D)
 Cord: 2100 mm
 Fitting: G9 (Light bulb not included)

Colors: Black BSNO1003 ●

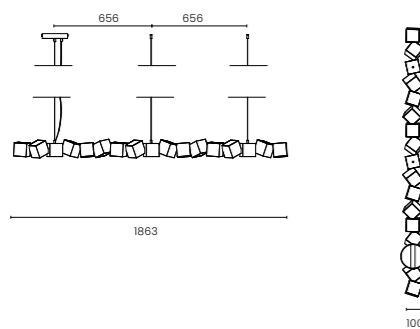

Blockchain 17 (2019) P.8

Markus Johansson, Sweden

Description: Pendant lamp providing downlight from every second LED driver (trailing edge) is provided and fitted in the canopy. Steel wire suspensions and transparent cable.

Environment: Indoor
 Watt: 9 x 5 W
 Measurements: 1863 mm (L), 100 mm (W), 100 mm (H)
 Cord: 300 cm
 LED info:* LED (replacable-spare part)
 lm output 4050 lm , CCT 3000K, SDCM 3, CRI 90, L90>100.000h, Driver: Pushdim, DALI

Colors: Black MJBL2003-X17 ●
 Blue MJBL2006-X17 ●

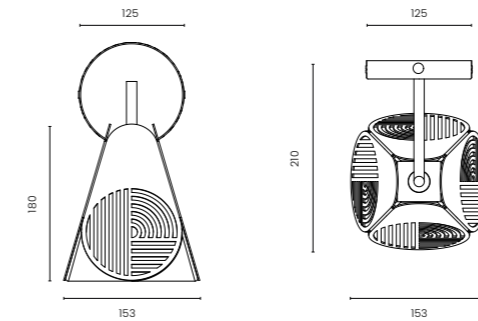

Notch Wall (2019) P. 79

Notchi (Sweden)

Description: Wall lamp in patterned steel and casted opal glass. Complex geometry, textile cord.

Environment: Indoor
 Watt: Max 25 W
 Measurements: 180 mm (H), 153 mm (W), 153 mm (D), 210 mm (From wall to edge of the shade)
 Fitting: G9 (Light bulb not included)

Colors: Black BSNO4003 ●

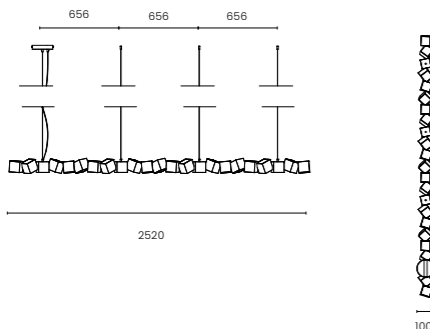

Blockchain 23 (2019) P. 6

Markus Johansson (Sweden)

Description: Pendant lamp providing downlight from every second cubes. Dimmable LED driver (trailing edge) is provided and fitted in the canopy. Steel wire suspensions and transparent cable.

Environment: Indoor
 Watt: 12 x 5 W
 Measurements: 2520 mm (L), 100 mm (W), 100 mm (H)
 Cord: 300 cm
 LED info:* LED (replacable-spare part)
 lm output 5400 lm , CCT 3000K, SDCM 3, CRI 90, L90>100.000h, Driver: Pushdim, DALI

Colors: Black MJBL2003-X23 ●
 Blue MJBL2006-X23 ●

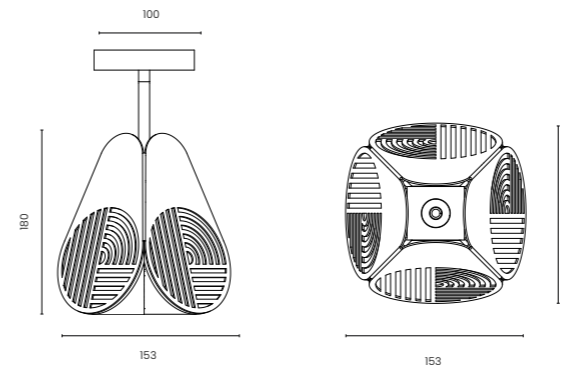

Notch Ceiling (2019) P. 80

Notchi (Sweden)

Description: Ceiling lamp in patterned steel and casted opal glass. Complex geometry, textile cord.

Environment: Indoor
 Watt: Max 25 W
 Measurements: 180 mm (H), 153 mm (W), 153 mm (D)
 Cord: 300 cm
 Fitting: G9 (Light bulb not included)

Colors: Black BSNO2003 ●

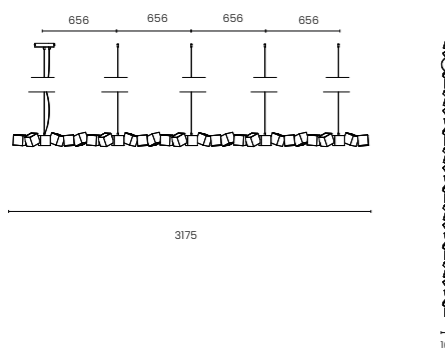

Blockchain 29 (2019) P. 7

Markus Johansson, Sweden

Description: Pendant lamp providing downlight from every second cubes. Dimmable LED driver (trailing edge) is provided and fitted in the canopy. Steel wire suspensions and transparent cable.

Environment: Indoor
 Watt: 15 x 5 W
 Measurements: 281 (H), 374 mm (∅)
 Cord: 300cm
 LED info:* LED (replacable-spare part)
 lm output 6750 lm , CCT 3000K, SDCM 3, CRI 90, L90>100.000h, Driver: Pushdim, DALI

Colors: Black MJBL2003-X29 ●
 Blue MJBL2006-X29 ●

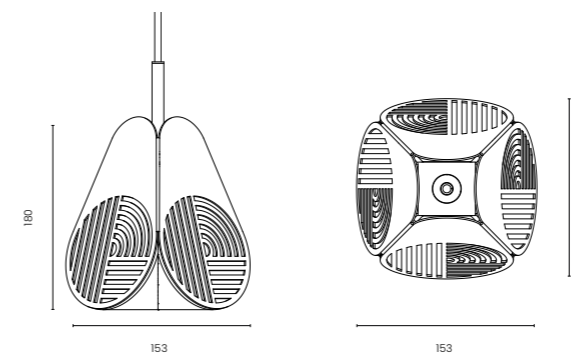

Notch Pendant (2019) P. 80

Notchi (Sweden)

Description: Pendant lamp in patterned steel and casted opal glass. Complex geometry, textile cord.

Environment: Indoor
 Watt: Max 25 W
 Measurements: 180 mm (H), 153 mm (W), 153 mm (D)
 Cord: 300 cm
 Fitting: G9 (Light bulb not included)

Colors: Black BSNO2003 ●



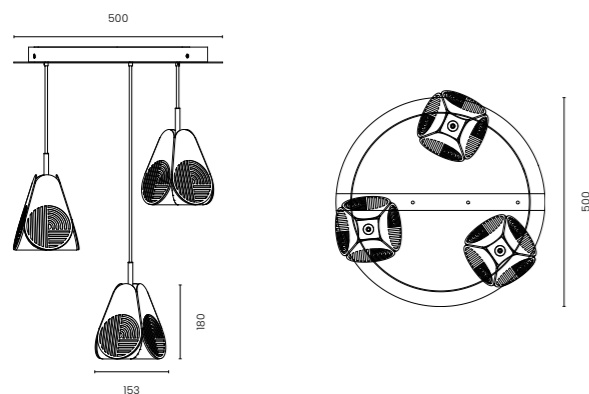

Notic Tripplette (2019) P. 80

Notchi (Sweden)

Description: Configuration of three Notic pendant lamps. Made in patterned steel and casted opal glass. Complex geometry, textile cord.

Environment: Indoor
 Watt: Max 3 x 25 w
 Measurements: 475 mm (H), 153 mm (W), 153 mm (D), Canopy: 500 mm (Ø), 38 mm (H)
 Cord: 300 cm
 Fitting: 3 x G9 (Light bulb not included)

Colors: Black BSNO2003-X3

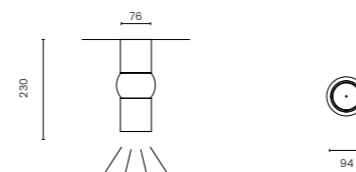

Lightbone Small Ceiling lamp (2023) P. 21

FÄRG & BLANCHE (Sweden/France)

Description: Ceiling lamp in solid oak wood, opal glass as a connection for ambient light, downlight with reflector for direct light. The color versions are made with linseedoil.

Environment: Indoor
 Measurements: 230 mm (H) x 94 mm (Ø),
 LED info*: 3 W & 10 W LED,
 Beam angle: Spot, Medium, Wide
 lm output 250lm & 1000 lm, CCT 2700K,
 CRI 90, SDCM 3, L80>50.000h, Driver: Phase cut dimmable

Colors: Black oak FBI2003.S
 Blue oak FBI2006.S
 Natural oak FBI2013.S

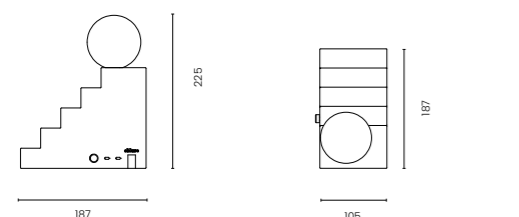

Stair Table (2022) P. 33

Notchi Architects (Sweden)

Description: Table lamp in steel and opal glass sphere equipped with G9 socket and rotary dimmer switch. The lamp also features with 2 x USB C charging ports and an hidden power outlet underneath.

Environment: Indoor
 Watt: Max 3 W (LED)
 Measurements: 225 mm (H), 187 mm (L), 105 mm (W)
 Cord: 300 cm
 Fitting: G9 (Light bulb not included, use a dimmable light bulb.)
 Futures: 2 x USB-C charging & 1 power outlet (230V)

Colors: Black NAST1003
 Beige NAST1004
 Yellow NAST1005
 Red NAST1007

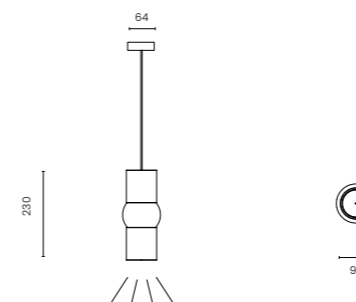

Lightbone Small Pendant lamp (2023) P. 19

FÄRG & BLANCHE (Sweden/France)

Description: Pendant lamp in solid oak wood, opal glass as a connection for ambient light, downlight with reflector for direct light. The color versions are made with linseedoil.

Environment: Indoor
 Measurements: 230 mm (H) x 94 mm (Ø),
 Cord: 300cm
 LED info*: 3 W & 10 W LED,
 Beam angle: Spot, Medium, Wide
 lm output 250lm & 1000 lm, CCT 2700K,
 CRI 90, SDCM 3, L80>50.000h, Driver: Phase cut dimmable

Colors: Black oak FBI2003.S
 Blue oak FBI2006.S
 Natural oak FBI2013.S

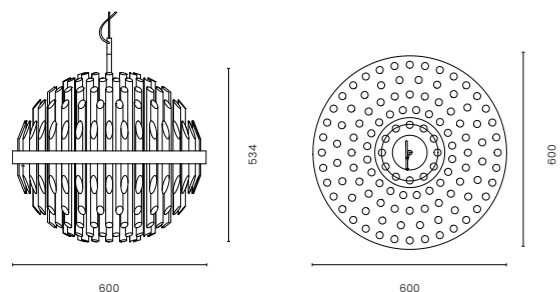

Helios (2020) P. 71

Joakim Thedin (Sweden)

Description: Modern chandelier made from acrylic glass and chrome plated steel. 240 transparent rods, each lit with a LED.

Environment: Indoor
 Watt: Max 2 x 20 W
 Measurements: 534 mm (H), 600 mm (Ø)
 Cord: 400 cm
 LED info*: LED (replacable-spare part)
 lm output 3600 lm, CCT 2700K, SDCM 3, CRI 80,
 L80>50.000h, Driver: Phase cut dimmable

Colors: Chrome JTHE2011

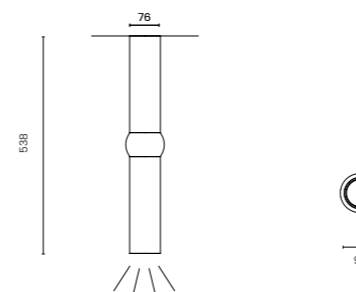

Lightbone Medium Ceiling lamp (2023) P. 20

FÄRG & BLANCHE (Sweden/France)

Description: Ceiling lamp in solid oak wood, opal glass as a connection for ambient light, downlight with reflector for direct light. The color versions are made with linseedoil.

Environment: Indoor
 Measurements: 230 mm (H) x 94 mm (Ø),
 LED info*: 3 W & 10 W LED,
 Beam angle: Spot, Medium, Wide
 lm output 250 lm & 1000 lm, CCT 2700K,
 CRI 90, SDCM 3, L80>50.000h, Driver: Phase cut dimmable

Colors: Black oak FBI2003.M
 Blue oak FBI2006.M
 Natural oak FBI2013.M

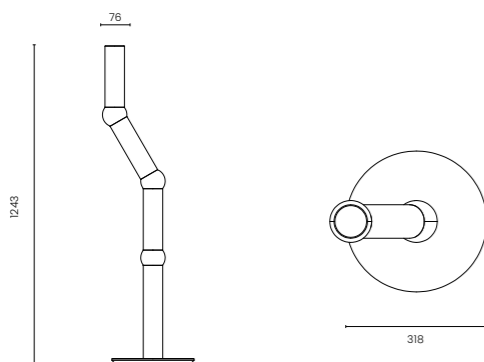

Lightbone Floor lamp (2023) P. 16

FÄRG & BLANCHE (Sweden/France)

Description: Floor lamp in solid oak wood, opal glass as connections, recessed solid brass plate on top as a rotating dimmer switch. The color version are made with linseedoil.

Environment: Indoor
 Watt: Max 3 x 3 w
 Measurements: 1243 mm (H) x 318 mm (Ø Base), 76 mm (Ø Pipe)
 Cord: 180cm
 LED info*: LED (replacable-spare part)
 lm output 750 lm, CCT 2700K, SDCM 3,
 CRI 90, L90>50.000h, rotary dimmer switch.

Colors: Blue oak FBI3006
 Black oak FBI3003
 Natural oak FBI3013

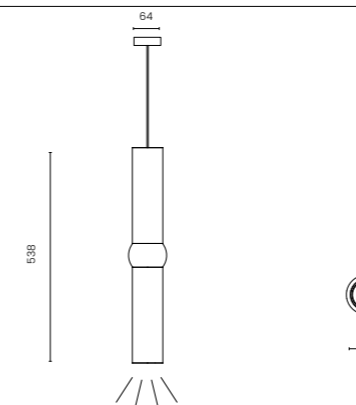

Lightbone Medium Pendant lamp (2023) P. 20

FÄRG & BLANCHE (Sweden/France)

Description: Pendant lamp in solid oak wood, opal glass as a connection for ambient light, downlight with reflector for direct light. The color versions are made with linseedoil.

Environment: Indoor
 Measurements: 230 mm (H) x 94 mm (Ø),
 Cord: 300cm
 LED info*: 3 W & 10 W LED,
 Beam angle: Spot, Medium, Wide
 lm output 250 lm & 1000 lm, CCT 2700K,
 CRI 90, SDCM 3, L80>50.000h, Driver: Phase cut dimmable

Colors: Black oak FBI2003.M
 Blue oak FBI2006.M
 Natural oak FBI2013.M



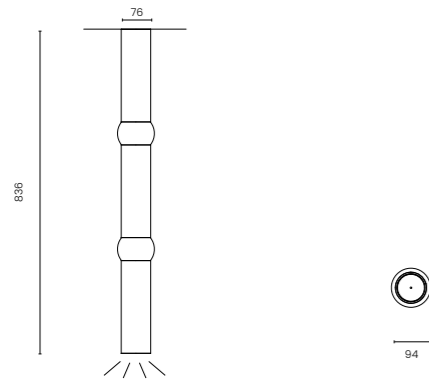

Lightbone Large Ceiling lamp (2023) P. 22

FÄRG & BLANCHE (Sweden/France)

Description: Ceiling lamp in solid oak wook, opal glass as a connection for ambient light, downlight with reflector for direct light. The color versions are made with linseedoil.

Environment: Indoor
 Measurements: 230 mm (H) x 94 mm (Ø),
 LED info*: 2 x 3 W & 10 W LED,
 Beam angle: Spot, Medium, Wide
 lm output 2 x 250lm & 1000 lm , CCT 2700K,
 CRI 90, SDCM 3, L80>50.000h, Driver: Phase cut
 dimmable

- Colors: Black oak FBIJ2003.L ●
 Blue oak FBIJ2006.L ●
 Natural oak FBIJ2013.L ●

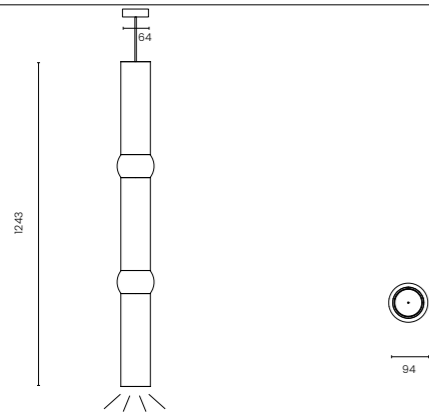

Lightbone Large Pendant lamp (2023) P. 24

FÄRG & BLANCHE (Sweden/France)

Description: Pendant lamp in solid oak wook, opal glass as a connection for ambient light, downlight with reflector for direct light. The color versions are made with linseedoil.

Environment: Indoor
 Measurements: 230 mm (H) x 94 mm (Ø),
 Cord: 300cm
 LED info*: 2 x 3 W & 10 W LED,
 Beam angle: Spot, Medium, Wide
 lm output 2 x 250lm & 1000 lm , CCT 2700K,
 CRI 90, SDCM 3, L80>50.000h, Driver: Phase cut
 dimmable

- Colors: Black oak FBIJ2003.L ●
 Blue oak FBIJ2006.L ●
 Natural oak FBIJ2013.L ●

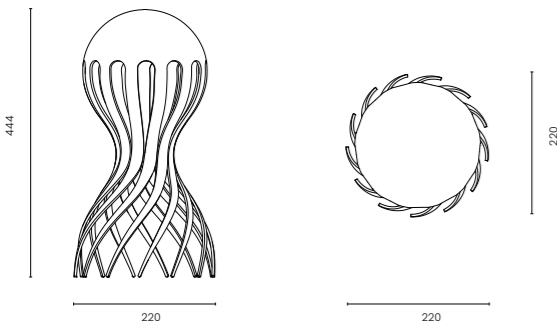

Cirrata Table (2011) P. 75

Markus Johansson (Sweden)

Description: Table lamp is made in aluminum with a decorative light effect. Textile cable with dimmer switch. Interchangeable multi wall plug adapter for multi country use.

Environment: Indoor
 Watt: 3.2 W
 Measurements: 444 mm (H), 220 mm (Ø)
 Cord: 180cm
 Fitting: LED (replaceable) 2700K

- Colors: White MJCII001 ○
 Grey MJCII002 ●

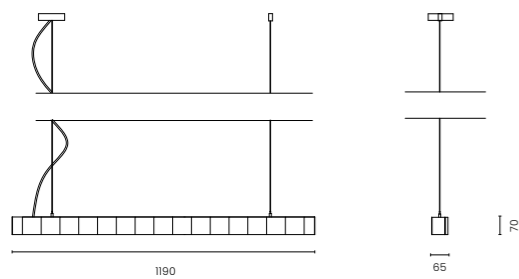

Superwave Pendant (2024) P. 27

Notchi Architects (Sweden)

Description: Pendant lamp in wave shape body and anti glare louvres. Downlight and uplight with suspension steel wire griplock® and transparent cable. External driver inside ceiling canopy.

Environment: Indoor
 Watt: 80 W
 Measurements: 1190 mm (L), 70 mm (H), 65 mm (W)
 Cord: 300cm
 LED info*: 20W uplight 2000lm, 50W downlight
 4000lm, CCT 3000K, CRI 90, SDCM 3, L90>100.000h.

- Colors: White NASW2001 ○
 Black NASW2003 ●
 Mintgreen NASW2007 ●
 Lilac NASW2014 ●
 Custom NASW2000.XX ●



LED info*: Updated and detailed information, please see product sheet or website.

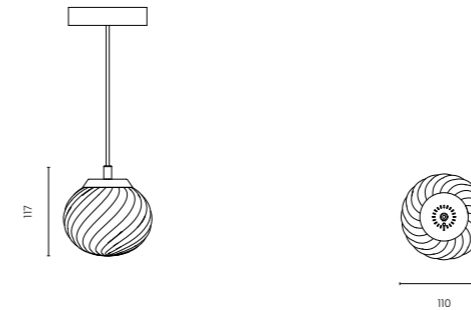

Inside 2.0 Single (2017) P. 85

Morten & Jonas (Norway)

Description: The pendant consist with a twisted glass. The light diffuses and spread a gentle wave pattern.

Environment: Indoor
 Watt: Max 5 W
 Measurements: 117 mm (H) 110 mm (Ø)
 Cord: 300cm
 LED info*: 5 W, lm output 750lm, opal, CCT
 2700K, CRI 90, SDCM 3, L80>50.000h, Driver:
 Phase cut dimmable

- Colors: Black MJIN2000 ●

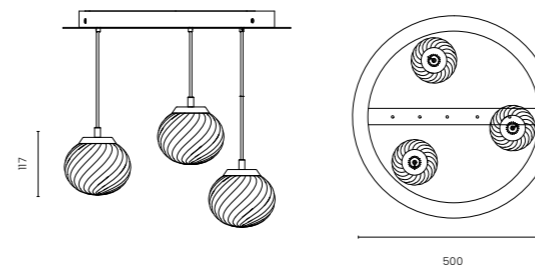

Inside 2.0 Triplette (2017) P. 86

Morten & Jonas (Norway)

Description: The pendant consist with a twisted glass. The light diffuses and spread a gentle wave pattern. Ceiling canopy pre set positions for tripple hanging.

Environment: Indoor
 Watt: Max 3 x 5 W
 Measurements: 500 mm (W) x 94 mm (Ø)
 Cord: 300 cm
 LED info*: 3 x 5 W, lm output 750lm, opal,
 CCT 2700K, CRI 90, SDCM 3, L80>50.000h,
 Driver: Phase cut dimmable

- Colors: Black MJIN2000-X3 ●



LED info*: Updated and detailed information, please see product sheet or website.

WHERE TO FIND US

WWW.OBLURE.COM

HEADQUARTERS

OFFICE
FABRIKSGATAN 38
41251 GOTHENBURG
TEL. +46(0)31-797 98 96

SHOWROOM

STAMPGATAN 8 EXTENDED
STAMPGATAN 8
41103 GOTHENBURG
TEL. +46(0)72-209 02 40

AGENTS

FINLAND + BALTICUM / NONEKA OY, PETRI PUOTINIEMI
INFO@NONEKA.FI, +358 40 060 4208

FRANCE / ROZENO, CORENTIN CADORET
C.CADORET@ROZENO.FR, +337 61 54 03 62

GREECE / THEODOROS ARCHONTIKIS
INFO@ARCHONTIKIS.COM, +306 908 401 825

POLAND, CZECHIA, SLOVAKIA, HUNGARY / PORTFOLIO, ANDZREJ ZYCH
ANDRZEJ@PORTFOLIO.PL, +48 604 063 464

PORTUGAL / SWYTCH DESIGN AGENCY PETER GALLET
PETER@SWYTCH.BE, +32 495 111 276

CREDITS

SPECIAL THANKS TO:

STINA NORLIN, ALICE JOHANSSON, ADORE ADORE,
JOHAN BERGREN, TEKLAN, KAJSA JOHANSSON, KRISTIAN LANTZ
NORDISKA GALLERIET, INPUT INTERIOR

ART DIRECTOR

MARKUS JOHANSSON DESIGN

EDITION

©2023 ALL RIGHTS RESERVED

oblure

OBLURE AB | FABRIKSGATAN 38 | 412 51 GOTHENBURG | SWEDEN
WWW.OBLURE.COM | INFO@OBLURE.COM
+46(0)31-797 98 96